

Telex

Operating Instructions



RadioCom™

BTR-700, TR-700

Professional Wireless Intercom System

TELEX®

Thank you for choosing RadioCom™

Telex Communications would like to take this opportunity to thank you for choosing the RadioCom™ BTR-700 Professional Wireless Intercom System. Many of the features in this product are the result of years of development work with many of the features developed from customer feedback. We hope that your experience with this product is a pleasant one and hope to provide you with a continuing line of RadioCom™ products well into the future. In order to get the most out of your new wireless intercom system, please take a few moments to look through this booklet before using the product for the first time.

-Telex Communications, Inc.

Table of Contents

Introduction	1-1
General Description	1-1
System Features	1-1
BTR-700 Block Diagram	1-2
BTR-700 Base Station	2-1
Controls and Connections - Front Panel	2-1
Controls and Connections - Rear Panel	2-2
BTR-700 Specifications	2-3
TR-700 Beltpack	3-1
Controls and Connections - Top Panel	3-1
Controls and Connections - Rear Panel	3-2
TR-700 Specifications	3-3
Initial Equipment Set-Up	4-1
Unpacking	4-1
Antenna Connections	4-2
Antenna Polarization	4-2
Distance Between Antennas	4-2
Antenna Placement	4-2
Improving Reception/Increasing Range	4-4
Base Station Set-Up	4-5
Location	4-5
Power Connection	4-5
Transmit Switches	4-5
Intercom Switch	4-6
Intercom Interface	4-6
Auxiliary Input/Output	4-7
Beltpack Set-Up	4-8
Battery Installation	4-8
Antenna Connection	4-9
Transmit Mode	4-9
Headset Connection	4-9
Pre-Walk-Thru Checklist	5-1
System Operation	6-1
Frequency Plan Overview	6-1
Factory-Defined Groups	6-1
User-Programable Groups	6-1
System Quick Start	6-1
Base Station Operation	6-2
Power	6-2
Local Headset	6-2
Portable Station Connect	6-2
Intercom	6-2
Auxiliary	6-2
Display Contrast	6-3
BTR-700 Menu Structure	6-4
Main Screen Flowchart	6-4
Power-Up Screen	6-5
Operating Screen	6-5
Beltpack Activity Code Definitions	6-5
Group/Channel Select	6-6
Group/Frequency Select	6-7
Frequency Edit	6-8
Clear Scan	6-9
Special Key Sequences	6-10
Lockout	6-10
Copy	6-10
1st Use Default	6-10
Factory Default	6-10

Table of Contents (continued)

Beltpack Operation	6-11
Power/Local Headset Volume	6-11
Battery Check	6-11
Talk Button	6-11
Microphone Gain	6-11
Beltpack Menu Structure	6-12
Power-Up Screens	6-13
Group/Channel Screen	6-14
Transmit Screen	6-15
Receive Screen	6-16
ClearScan™	6-17
Talk Button Latch on/Latch off	6-18
Special Key Sequences	6-18
Lockout	6-18
1st Use Default	6-18
Factory Default	6-18
System Walk-Thru	7-1
Trouble Shooting	8-1
Tech Tips	9-1
Frequency Interaction	9-1
Microphone Gain Adjustment	9-1
Battery Information	10-1
Intercom System Specifications	11-1
Accessories and Replacement Parts	12-1
Customer Service Information	13-1
Software License	14-1
Certification Information	15-1
Limited Warranty	16-1

Section 1 Introduction

General Description

The Telex RadioCom™ BTR-700 UHF Synthesized Wireless intercom systems offer the ultimate in reliable, high performance, high fidelity full duplex communications.

The BTR-700 system includes the BTR-700 frequency agile base station, working with up to four TR-700 frequency agile beltacks. The BTR-700 base station provides full duplex communications with the beltacks.

The BTR-700 system is perfectly suited for stand-alone operation and also can interface with Audiocom® (Telex), RTS® TW, ClearCom® as well as RTS Matrix systems and other 4 wire communications systems. In addition to the external intercom systems interfaces listed above, the system provides connections for auxiliary balanced audio input and output.

The RadioCom™ BTR series has been designed for reliable, efficient operation. Operating in the 518 to 740 MHz range, the units operate reliably at line-of-sight distances of 1,000 feet. With available antenna systems from Telex, the effective operating range can be extended. The high efficiency beltacks provide 12 hours of uninterrupted operation using standard alkaline batteries.

System Features

- Frequency agile base station and beltacks. No external computer/device required to select frequencies.
- Backlit base station LCD allows the user to easily monitor the beltack's status as well as change base station frequencies.
- ClearScan™ function on base station and beltack to automatically find the best channels on which to operate.
- Full duplex (simultaneous talk and listen) operation.
- Compatible with Audiocom® (Telex), RTS TW, RTS Matrix, Clear-Com®, and other wired intercom types.
- Beltack units contained in a weather and shock resistant die cast magnesium case.
- Convenient IEC power connector on the base station so the unit can plug directly to outlets. No in-line or wall plug power supply.
- Base station comes with rack ears for easy rack mounting.
- Beltack batteries last up to 12 hours when using standard AA alkaline batteries.

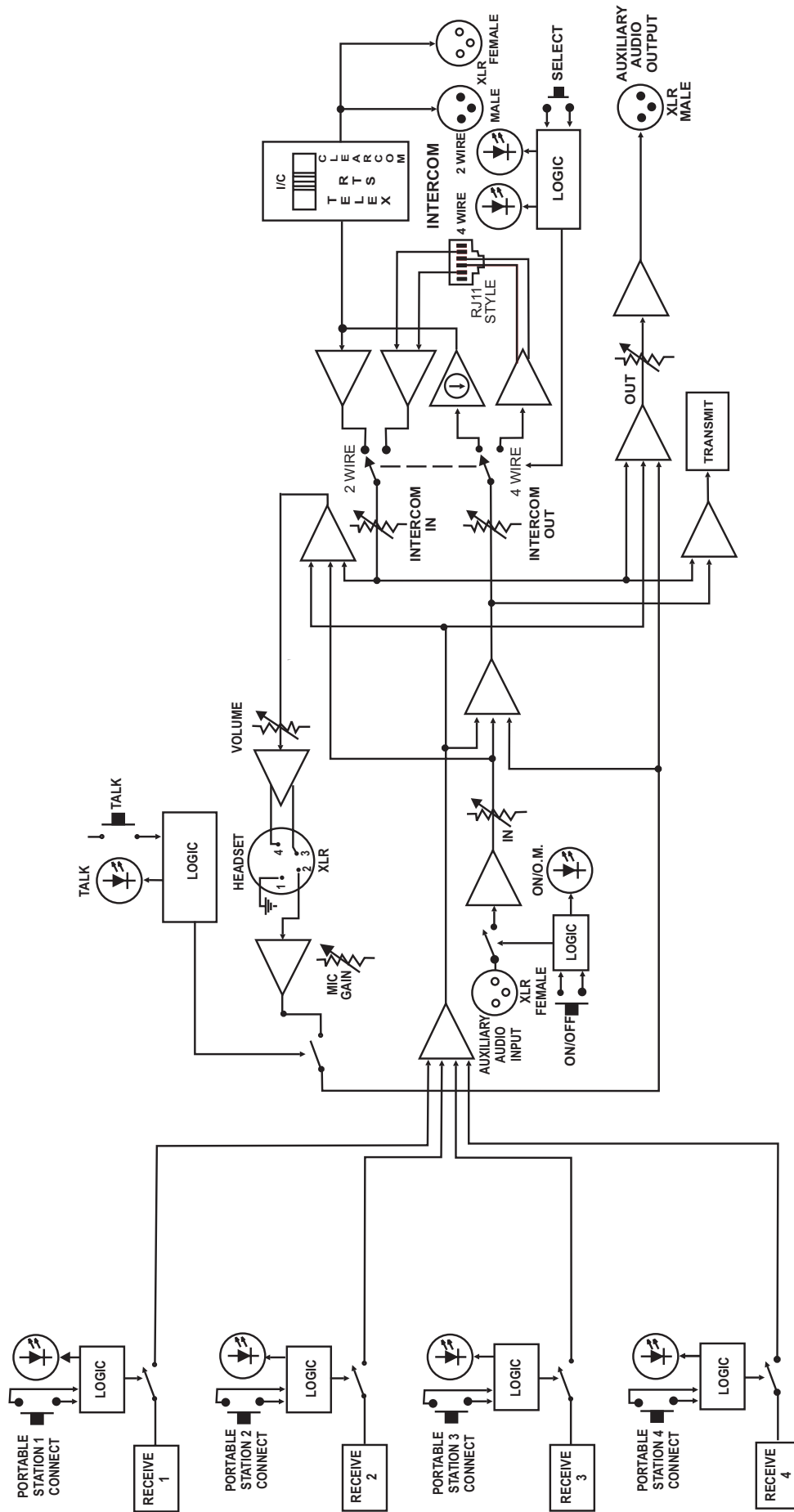

BTR-700 Block Diagram

Section 2 BTR-700 Base Station

Controls and Connections - Front Panel

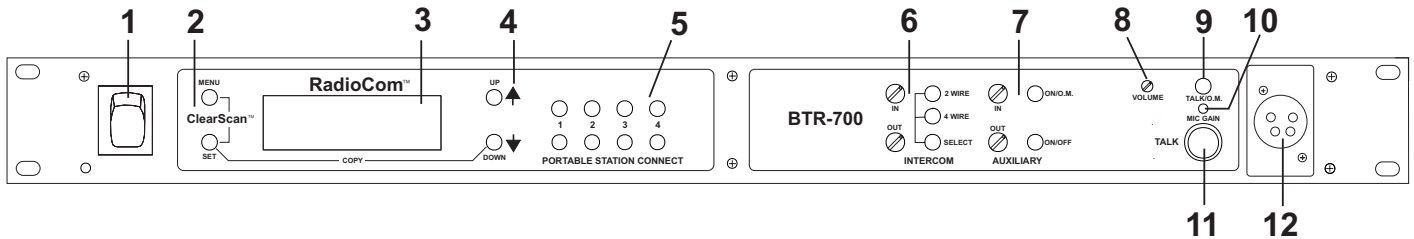
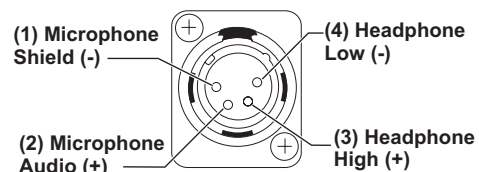

Figure 1
BTR-700 - Front Panel

1. **Power switch.**
2. **[Menu] and [Set] buttons** – Used to select menus and set options on the LCD.
3. **Backlit Graphics LCD (Liquid Crystal Display).**
4. **[Up] and [Down] buttons** – Used to select base station options on the LCD.
5. **Portable Station Connect** – Buttons used to enable or disable the respective receiver’s audio. GREEN LED = Audio enabled, LED OFF = Audio disabled.
6. **Intercom Controls** - Wired intercom interface controls. Audio input and output level controls. 2-wire or 4-wire select button with green LED indicator lights. Selected LED will change to RED if the input levels are too high.
7. **Auxiliary Controls** - Wired auxiliary interface controls. Audio input and output level controls. GREEN LED = Aux. input enabled. LED will change to RED if the input levels are too high.
8. **Headset Volume** – Controls the volume to the headset connected to #12.
9. **Talk/Overmod Light** – LED is green when talk button #11 is active. A normal mic. gain setting will cause the LED to flash red on the loudest speech levels. If the gain is too high, the LED will be red at normal speech volumes.
10. **Microphone Gain** – Adjusts the headset’s microphone gain. Adjusts so that the overmod light #9 flashes from green to red on loudest speech.
11. **Talk Button** – Press to enable the audio path from the local headset. LED #9 will turn green when enabled. A quick press and release latches button on. If the talk function is latched on, pressing the talk button again will turn it off.
12. **Local Headset Connector** – Male XLR connector for Telex units, Female XLR connector for RTS units. A dynamic or electret headset microphone is automatically detected.

Telex Units



RTS Units

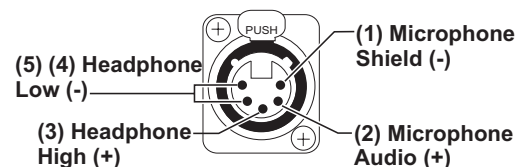
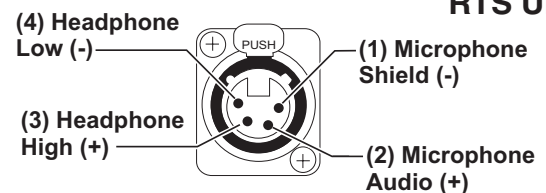

Figure 2
Local Headset Wiring

Controls and Connections - Rear Panel

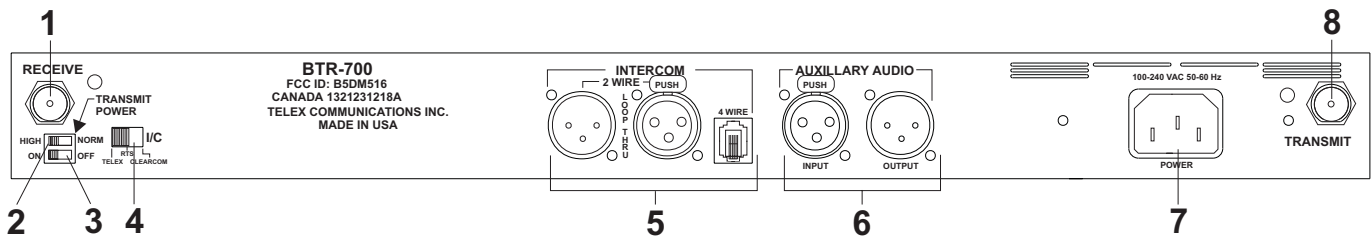

Figure 3
BTR-700 - Rear Panel

- 1. Receive Antenna** - Female "TNC" Connector. Color band on antenna must match color dot on base station.
- 2. Transmit Power Switch** – HIGH = Transmitter at full power. NORMAL = Transmitter 10dB below full power.
- 3. Transmit ON/OFF Switch** – Turns the transmitter on or off.
- 4. I/C Select Switch** – Set to the appropriate 2-wire intercom type being interfaced to the unit. Set to either Telex, RTS or ClearCom®.
- 5. Intercom** – Interface to wired intercom system .
 - 2-Wire** – Male and Female 3 pin XLR connectors wired in parallel. The connectors are switched to the appropriate intercom configuration via the I/C Select Switch.
 - 4-Wire** – An RJ-11 type jack compatible with "Matrix" type intercom systems.
- 6. Auxiliary Input/Output** – One 3 pin female XLR input connector and one 3 pin male XLR output connector.
- 7. Power** – IEC receptacle. Accepts 100 – 240VAC, 50 – 60 Hz
- 8. Transmit Antenna** - Female "TNC" Connector. Color band on antenna must match color dot on base station.

BTR-700 Specifications

Overall

RF Frequency Range	518 - 608 MHz, 614 - 740 MHz in 18 MHz TX and RX bands
Power Requirements	100-240 VAC, 50-60 Hz, IEC receptacle
Temperature Range	-4° F to 130° F (-20° C to 55° C)
Dimensions	19.00" W x 1.72" H x 14.00" D (48.3 cm x 4.4 cm x 35.6 cm)
Weight	7 lbs 2 oz (3.24 kg)
TX Antenna	1/2 Wave (supplied), TNC Male Connector
RX Antenna	1/2 Wave (supplied), TNC Male Connector
FCC ID:	B5DM516
Frequency Response	300-8kHz
Four Wire Input	Level Adjustable (2 Vrms typical)
Four Wire Output	Level Adjustable (2 Vrms typical)
Telex Intercom	Input/Output Level Adjustable (1 Vrms typical), Line impedance 300Ω
RTS Intercom	Input/Output Level Adjustable (0.775 Vrms typical), Line Impedance 200Ω
ClearCom® Intercom	Input/Output Level Adjustable (1 Vrms typical), Line Impedance 200Ω
Auxiliary Input	Adjustable (2 Vrms typical)
Auxiliary Output	Adjustable (2 Vrms typical into 600Ω)
Microphone input sensitivity	9mV
Local Headset Output	40mW output into 600Ω (1% Distortion)

Transmitter

Type	Synthesized Transmitter, 712 channels
Transmit Power	50mW Max. (High), 5 mW (Normal)
Modulation Type	FM
Deviation	40 kHz
RF Frequency Stability	0.005%
Modulation Limiter	Peak-Responding Compressor
Radiated Harmonics & Spurious	Exceeds FCC specifications

Receiver

Type	Dual Conversion Superheterodyne, four Independent Synthesized IFs, FM, 712 channels each
RF Sensitivity	<0.8 μV for 12 dB SINAD
Squelch Threshold	20 dB SINAD
IF Selectivity	3 dB at 230 kHz
Image Rejection	70 dB or better
Squelch Quieting	90 dB
RF Frequency Stability	0.005%
Distortion	<1% at full deviation

Section 3

TR-700 Beltpack

Controls and Connections - Top Panel

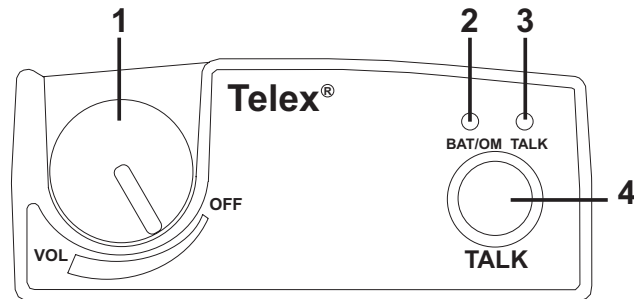

Figure 4
TR-700 Top Panel

- 1. On/Off & Volume Control** – Turns the beltpack power on and controls headset volume.
- 2. Bat/Overmod Light** – Light will flash once when unit is turned on if the battery is good. If the light stays on, battery is low. If the light does not flash, battery is dead. A normal microphone gain setting will cause the LED to flash at the beginning of most words at normal speech levels. If the gain is too large, the LED will be red during the complete word at normal speech levels.
- 3. Talk Light** – LED is on when the talk button is active.
- 4. Talk button** – Press to enable the audio path from the local headset microphone. The “TALK” LED, #3, will turn red when enabled. A quick press and release latches the talk function, unless latching has been disabled in software. Holding the button for over $\frac{1}{2}$ a second will cause the audio path to be enabled only for as long as the button is held. If the talk function is latched on, pressing the talk button again will turn it off.

Controls and Connections - Rear Panel

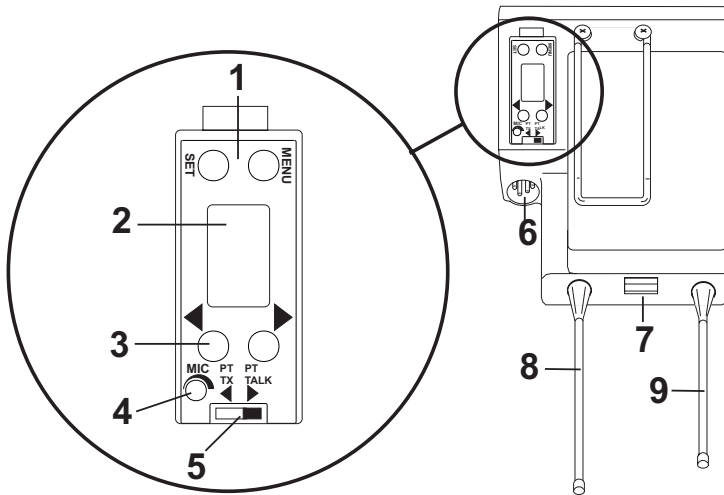

Figure 5
TR-700 Rear Panel/Connector/Antennas

1. **[MENU] and [SET] buttons** – Used to select menus and set options on the LCD.
2. **LCD (Liquid Crystal Display)**
3. **[UP] and [DOWN] buttons** – Used to select beltpack options on the LCD.
4. **Microphone Gain** – Adjusts the headset’s microphone gain. Adjust so that the BAT/OM LED will flash at the beginning of most words at normal speech levels
5. **Push-to-Talk/Push-to-Transmit Switch** –
 - Push-to-Talk (PT TALK)** – The transmitter is always on. No audio is sent unless the talk button is pressed. Recommended position.
 - Push-to-Transmit (PT TX)** - The transmitter and audio paths are off except when the talk button is pressed.

6. **Headset Connector** – Male XLR connector for Telex units, Female XLR connector for RTS units. A dynamic or electret headset microphone is automatically detected by the beltpack and a bias voltage supplied if needed.

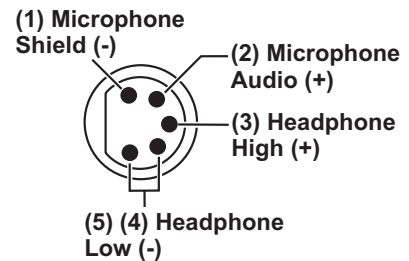
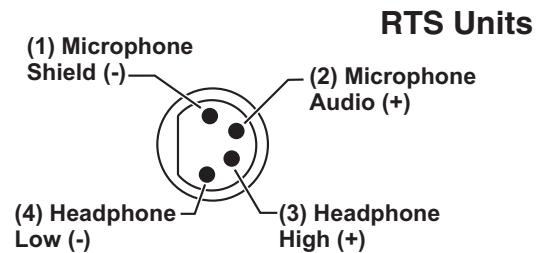
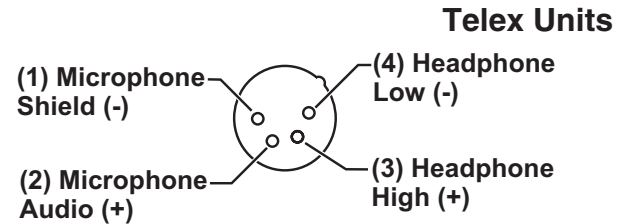

Figure 6
Headset Jack Wiring

7. **Battery Latch** – Press down to enable the battery pack to be released. While the latch is held down, slide the battery pack about 1/8 inch back, toward the latch, until it stops. Then lift out.
8. **Receive Antenna** – Screw type ¼ wave replaceable antenna. The receiver antenna is always the longer antenna. Color dot on the screw end of the antenna must match color dot on antenna receptacle.
9. **Transmit Antenna** – Screw type ¼ wave replaceable antenna. Color dot on the screw end of the antenna must match color dot on antenna receptacle.

TR-700 Specifications

RF Frequency Range	518 - 608 MHz, 614 - 740 MHz in 18 MHz TX and RX bands
Power Requirements	6 "AA" Cells Alkaline (NiMH optional)
Current Draw	140 mA (Push-to-Talk, Talk On)
Temperature Range	-4° F to 130° F (-20° C to 55° C)
Dimensions	3.75"W x 5.05"H x 1.65" D (9.5 cm x 12.8 cm x 4.2 cm)
Weight	16 oz (454g) with alkaline batteries
TX Antenna	1/4 Wave (supplied), Screw type, Replaceable
RX Antenna	1/4 Wave (supplied), Screw type, Replaceable
FCC ID:	B5DM515
Frequency Response	300-8kHz
Microphone input sensitivity	7 mV
Local Headset Output	40 mW output into 600 Ω (1% distortion)

Transmitter

Type	Synthesized, 712 channels
Transmit Power	50 mW Max. (auto-power reduction)
Modulation Type	FM
Deviation	40 kHz
RF Frequency Stability	0.005%
Modulation Limiter	Peak-Responding Compressor
Radiated Harmonics & Spurious	Exceeds FCC specifications

Receiver

Type	Dual Conversion Superheterodyne, Synthesized, FM, 712 channels
RF Sensitivity	<0.7 μ V for 12 dB SINAD
Squelch Threshold	20 dB SINAD (About 1.0 μ V)
IF Selectivity	3 dB at 230 kHz
Image Rejection	70 dB or better
Squelch Quieting	90 dB
RF Frequency Stability	0.005%
Distortion	<1% at full deviation

Section 4

Initial Equipment Set-Up

Unpacking

Unpack your RadioCom™ System. Below are the items that should come with your base station and each belt pack.

Contact the shipper or your dealer immediately if anything is damaged or missing. Fill out the registration card and return it to Telex to register the unit.

BTR-700

Quantity	Description
1	BTR-700 Base Station
1	Operating Instructions
1	Power Cord
2	Antennas (one Transmit and one Receive)
1	Warranty Card
1	Screw driver
1	Warning Card
4	Rubber feet

TR-700

Quantity	Description
1	TR-700 with Antennas
1	Battery pack
1	Instruction Sheet
1	Screw Driver
1	Warranty Card

Antenna Connection

The base station is supplied with two (2) antennas. One 1/2-wave antenna for Transmit and one 1/2-wave for Receive. The antennas have TNC male connectors.

The frequency range of the antennas should match the receiver and transmitter of the base station. Match the color code on the antenna with the color code on the base station.

Attach the transmit 1/2-wave antenna to the antenna input receptacle labeled "Transmit" on the right side of the rear panel. The antenna should be vertically aligned.

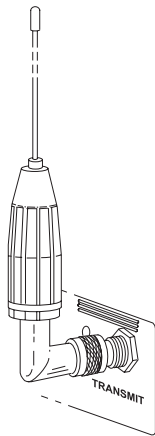

Figure 7
Attaching Transmit 1/2-Wave Antenna

Attach the receive 1/2-wave antenna to the antenna input receptacle labeled "Receive" on the left side of the rear panel. The antenna should be vertically aligned.

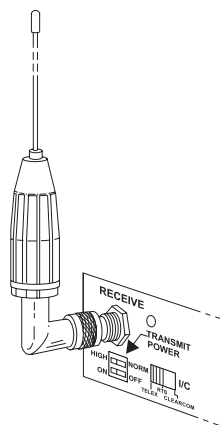

Figure 8
Attaching Receive 1/2-Wave Antenna

Antenna Polarization

The Telex Wireless Intercom System is "Vertically Polarized". This means both the transmitting and receiving antennas should operate in the vertical position.

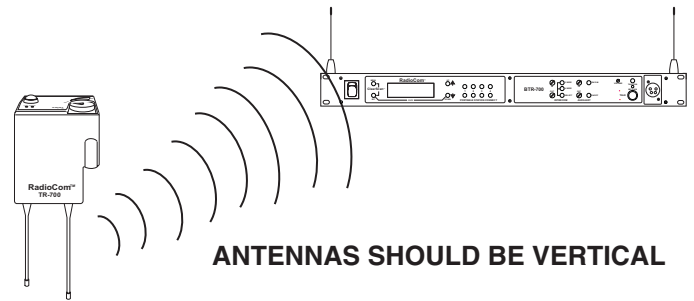

Figure 9
Vertically Polarized Antennas

Distance between Antennas

The distance between the base station's receive and transmit antennas is not adjustable when the antennas are connected directly on the back of the unit.

The antennas can be remoted for better signal path. A Telex coax assembly with remote antennas may be required. See "Accessory" section for ordering information.

NOTE: If your base station is to be located in a shielded rack mount enclosure or other poor RF location, you must remote the 1/2-wave antennas with coax assemblies. See "Accessories and Replacement Parts" section for remote mounting hardware.

Antenna Placement

Proper antenna placement probably has the most effect on your TELEX Wireless Intercom System's overall performance. The following suggestions will result in optimum performance.

Proper placement of the belt pack can be critical. The antennas should be in the open. Bending the antennas up and placing the belt pack in a pocket, etc., will reduce system distance.

It is suggested that the unit be worn on the belt or pocket with both antenna's vertical for best operating range and performance.

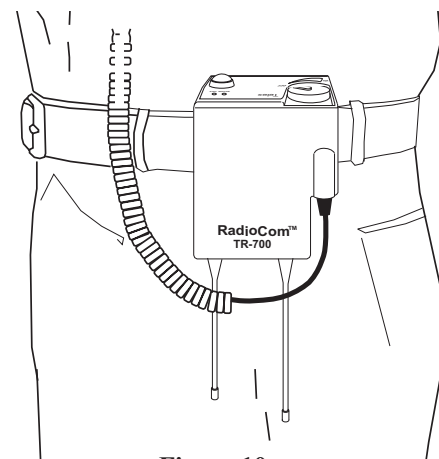

Figure 10
Proper Dressing of the Antennas

Keep the distance between the base station and the beltacks as short as possible. The greater the distance, the weaker the signal. Make sure the “signal paths” between the base station and beltacks are unobstructed. You should be able to visibly locate the base station antennas at all times for best performance.

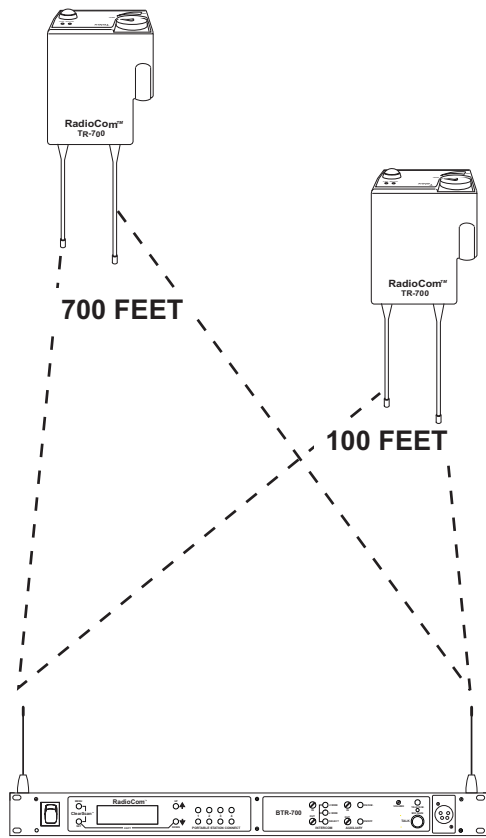

Figure 11
Distance Between base station and beltpack

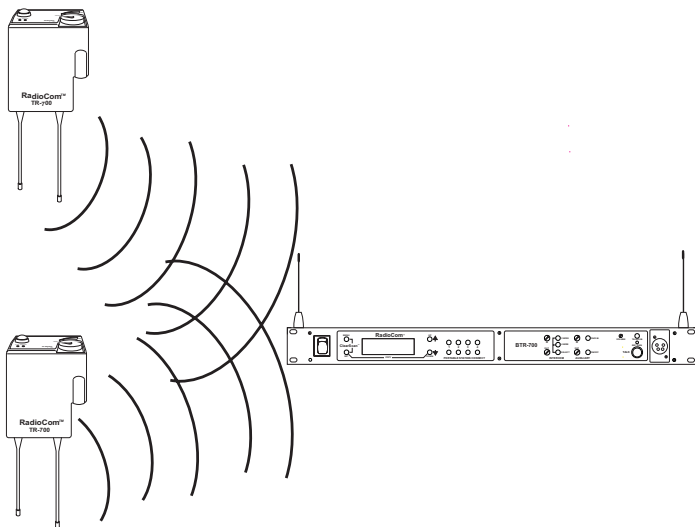

Figure 12
Keeping Site Clear to Antenna

Attempting to operate the wireless intercom system through or around walls, ceilings, metal objects, etc. will reduce system range and performance.

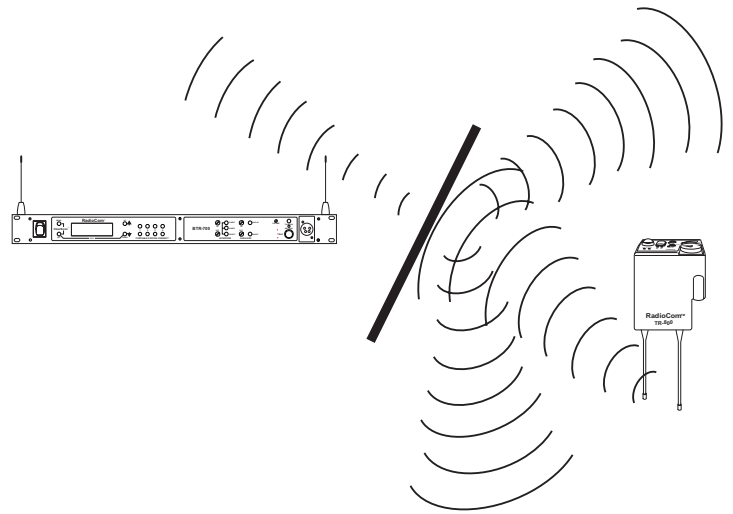

Figure 13
Operating System Near Obstructions

DO NOT - mount the base station 1/2-wave antennas on, or next to metal, such as beams, walls with metal studs, equipment racks, etc. This also applies to the antennas when assembled directly to the Base Station. This will “detune” the antennas which can result in noise or loss of RF signal at the Base Station, see Figure 13.

2. Placing the BTR on top of a shelf or equipment rack unobstructed without removing the antennas is OK.

1. Placing BTRs in a shelf or equipment rack and using remote antennas is OK.

3. Placing BTRs in a shelf or equipment rack with the antennas mounted on the back of the BTR or the side of the rack is **BAD**.

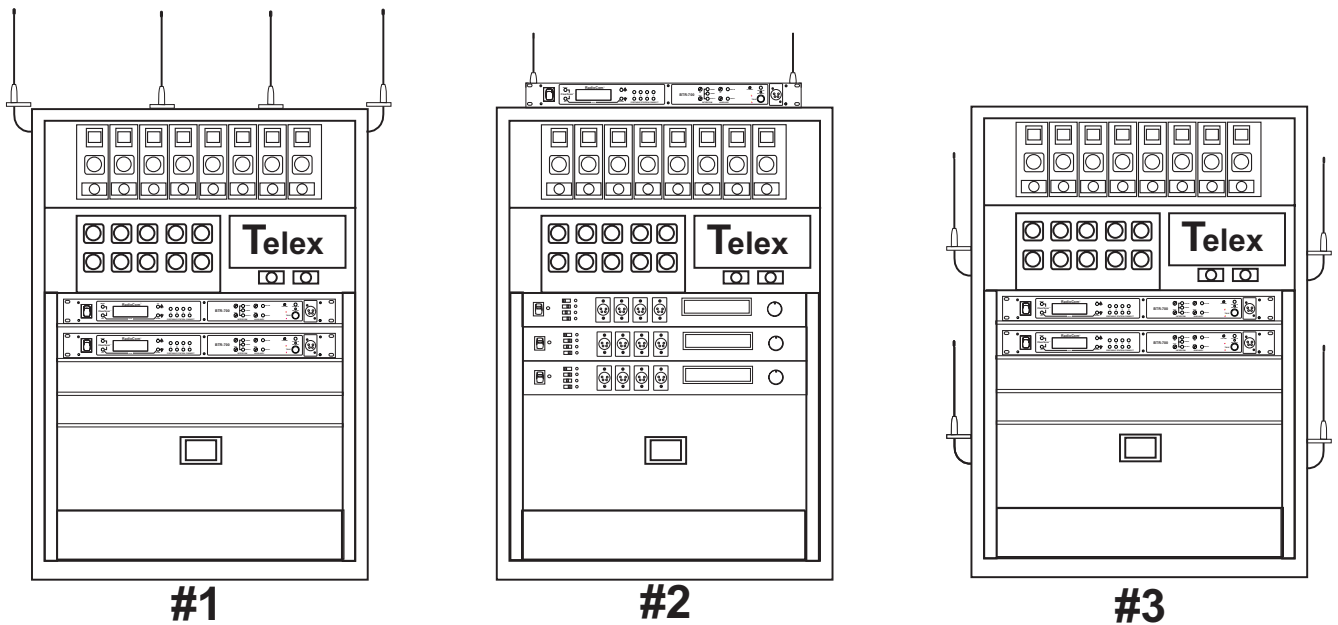

Figure 14
Antenna Placement

Improving Reception and Increasing Range

Keeping the distance from the base station and beltback as short, and unobstructed as possible will produce the most reliable performance.

The base station is supplied with two antennas. This should provide satisfactory system performance in most applications. System range can be enhanced by removing the 1/2-wave antennas.

Base Station Set-up

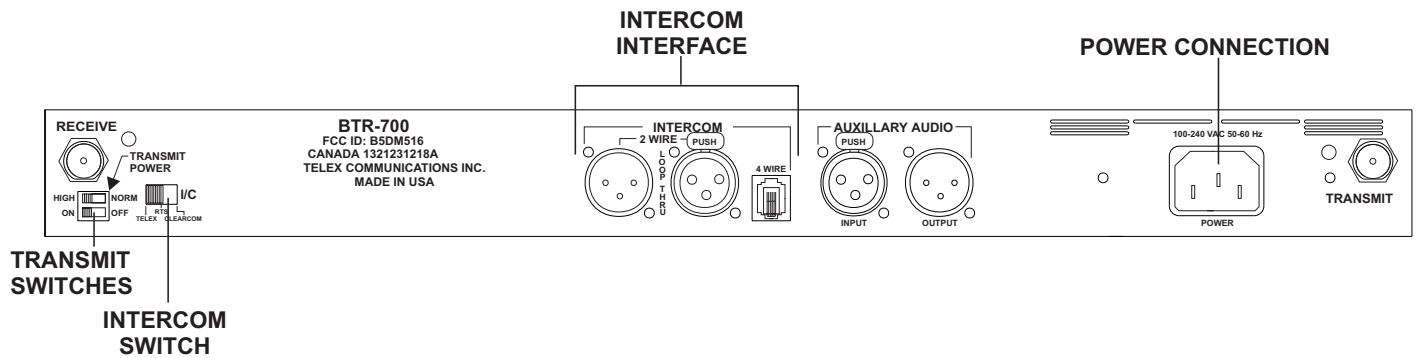

Figure 15
Base Station - Rear Panel

Location

Locate the base station with the front and rear of the unit accessible so that switches may be set and connections made. Place the transmit and receive antennas on the base station. Make sure the antenna's color band match the color dot near each antenna. See "Antenna Information" section for more information on choosing a proper operating location.

Power Connection

Plug the supplied power cord into the unit. The base station has an IEC power receptacle that accepts 100 – 240VAC, 50 – 60Hz. The specific receptacle type is an IEC 320/C14/3PIN. The cord it accepts is a C13. These cords are common and available through many retail hardware/electronic stores if the cord is lost.

Transmit Switches

There are two switches located on the lower left side of the rear panel. The upper switch sets the transmit power level to high or normal. The lower switch turns the transmitter on or off.

Transmit Power

Set the power level to normal if using the beltacks at close to medium distances (<200 feet, 161m, line-of-sight) from the base station. Set the power level to high if using the beltacks at a distance (>200 feet, 161m, line-of-sight) from the base station.

On/Off

Set the transmitter switch to on for normal use. In the off position the base station transmitter is disabled. Setting the switch to off will disables all the beltacks from hearing anyone else or even their own sidetone.

Intercom Switch

The Radiocom™ wireless system can be interfaced to RTS TW, Audiocom® (Telex), Clearcom®, RTS matrix and other intercom (I/C) systems. Set the Intercom switch on the rear of the unit to the appropriate system and connect the system to the base station. The intercom channel on the rear of the base station has loop-thru male and female XLR connections for two-wire systems and a RJ-11 type jack for four-wire systems.

This switch only affects the two-wire intercom systems. The functions of the I/C XLRs change depending on the intercom selected. Please see Section 11 for pinout information of the different two-wire intercom systems.

Intercom Interface

Telex (Audiocom®) and Clearcom® intercom systems require one cable for intercom. This interfacing is done through the I/C 3 pin XLR connectors on the rear of the unit.

RTS TW intercoms also only need to connect one 3 pin cable to one of the two intercom XLR connectors. Two channels of audio are carried on one cable for RTS. RTS channel 1 is placed on the intercom normally. Switch the rear panel I/C switch to Clearcom® to interface only to RTS audio channel 2. Once again, leave it in RTS to interface to only RTS audio Channel 1.

Four wire intercom systems require only one cable for the intercom to interface four wire intercom to the base station. This interfacing is done through the I/C RJ-11 type jacks on the rear of the unit. See Figure 16 for the pinout of the RJ-11 jacks.

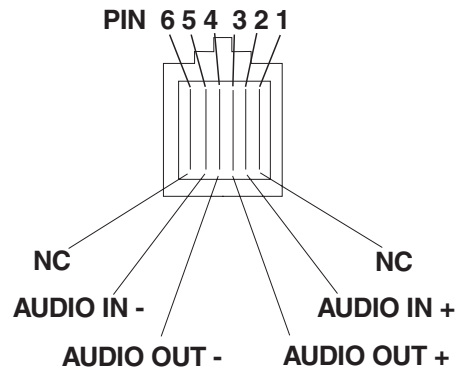

Figure 16
RJ-11 Type/ Four-wire Pinout

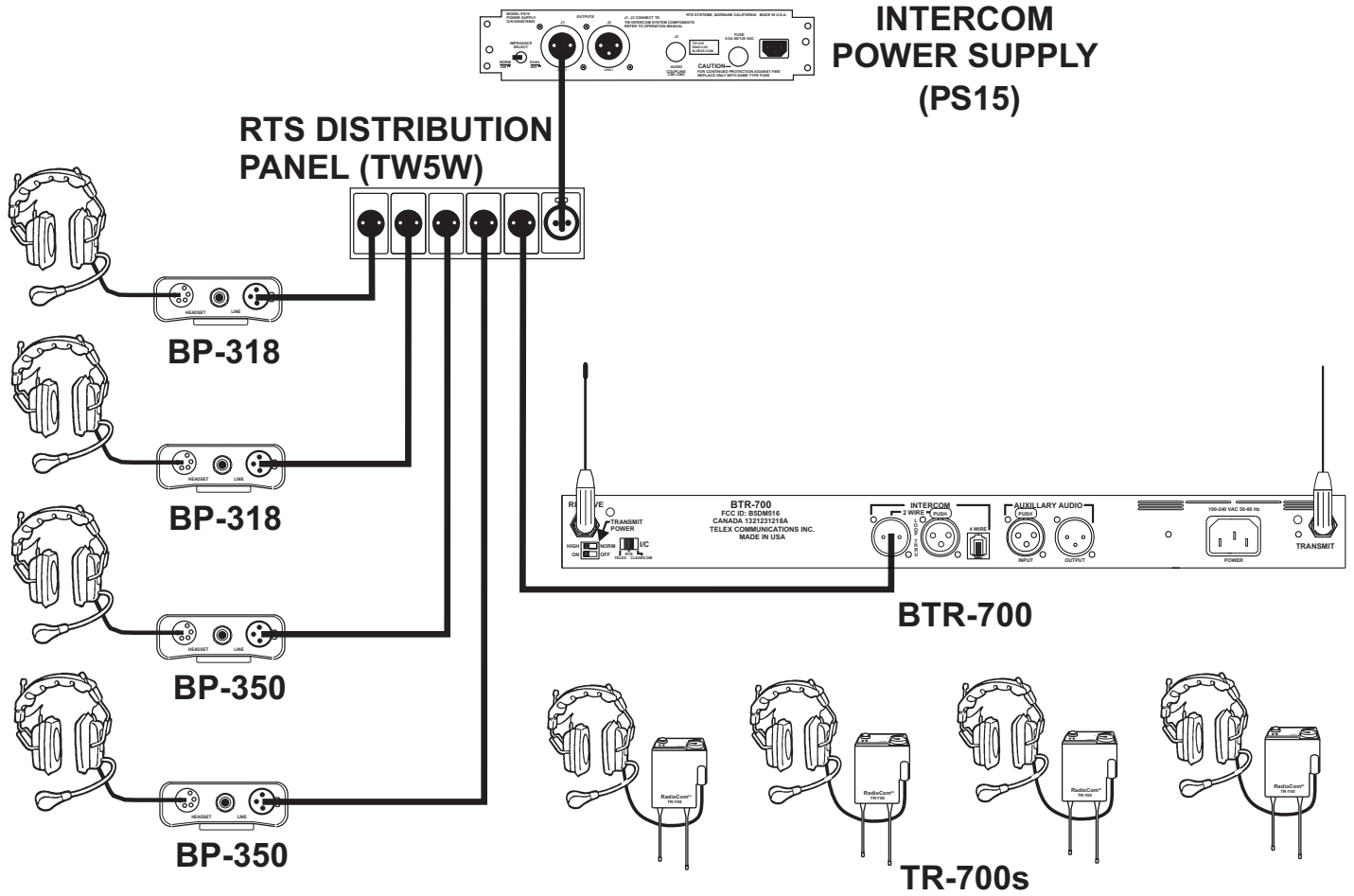
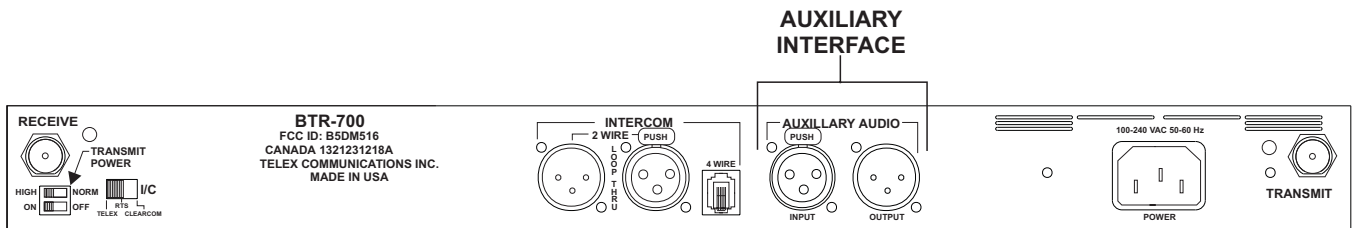

Figure 17
Example Interface to an RTS TW System



Base Station - Rear Panel

Auxiliary Input/Output

The input and output 3 pin auxiliary connections are for supplying additional balanced audio into and receiving balanced audio from the base station. This can also be used as another four-wire type interface to the base station.

Beltpack Set-up

Battery Installation

Insure that the On/Off volume control knob is turned off.
Press down and hold down the battery release latch, slide the battery pack about 1/8 inch back, toward the latch, until it stops. Then lift battery pack out. Replace batteries as follows:

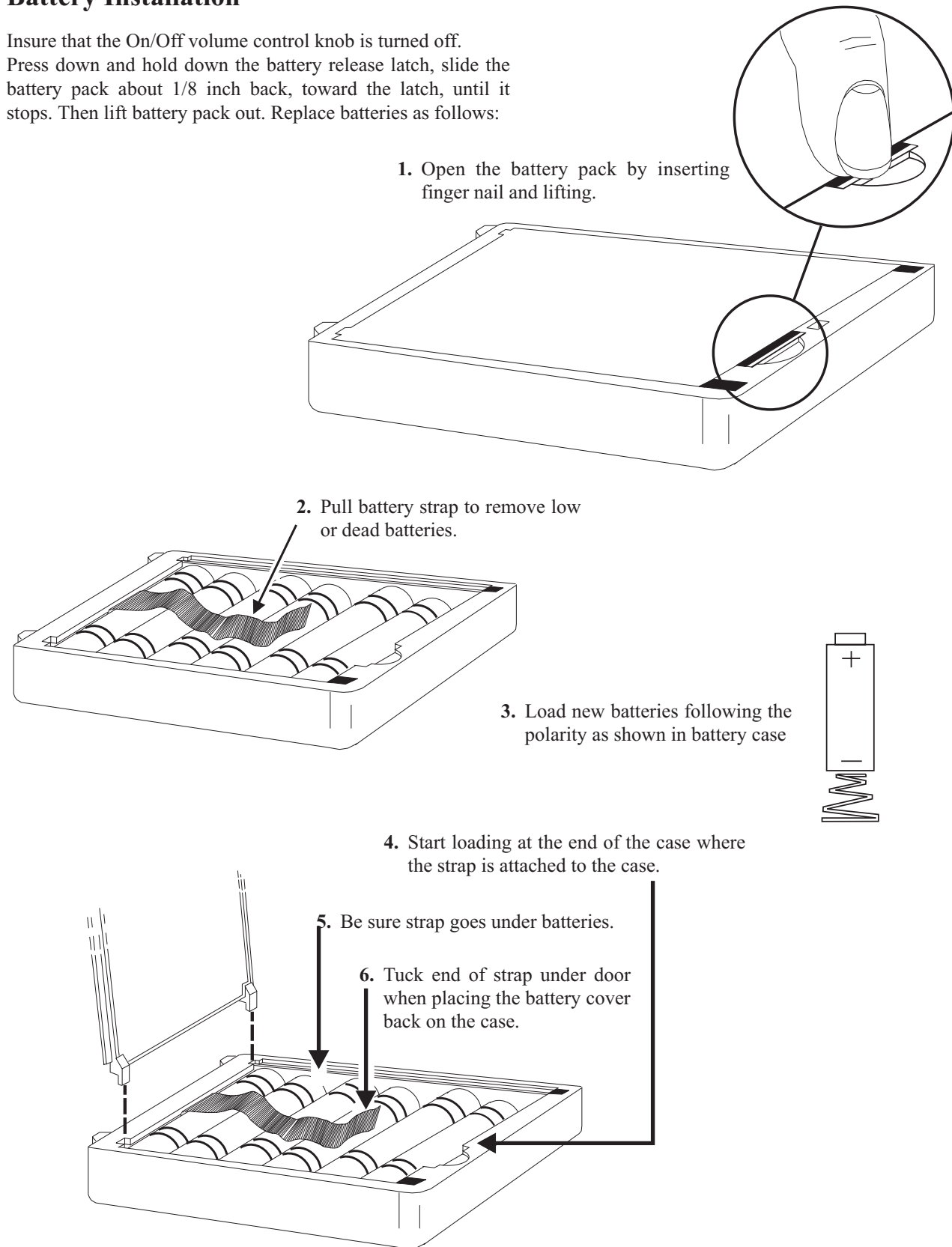

Figure 18
Battery Installation

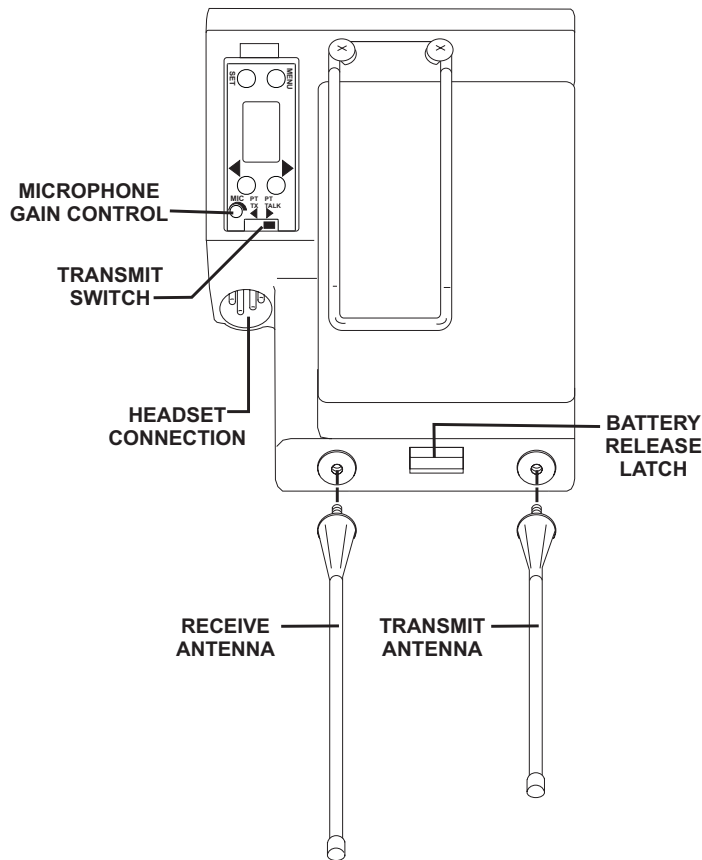

Figure 19
TR-700 Rear Panel

Antenna Connection

The beltpack comes with two detachable, screw type, $\frac{1}{4}$ wave antennas. To attach the two antennas, screw into the receptacles at the bottom of the beltpack. The color dot on the screw end of the antenna must match the color dot on antenna receptacle. The longest antenna is the receiver antenna. It screws into the left receptacle if the beltpack is laying flat with the battery compartment face up and the antenna receptacles facing you. The other antenna is the transmit antenna. New antennas can be ordered if desired, see the “Accessories” section.

Transmit mode

The rear panel located transmit switch has the following two modes:

Push-to-Talk (PT TALK) – Recommended position –
The transmitter is always on. No audio is sent unless the talk switch is pressed.

Push-to-Transmit (PT TX) – The transmitter and audio paths are off except when the talk switch is pressed.

Headset Connection

Insert the headset plug into the XLR connector. See the headset pinout in the “TR-700 beltpack controls and connections” section if this is not a Telex headset. A dynamic or electret headset microphone is automatically detected by the beltpack and a bias voltage supplied if needed.

Section 5 Pre-Walk-Thru Checklist

Following the instructions fully to this point you have successfully completed the following checklist:

- Located the base station properly.
- Connected power to base station.
- Connected the 1/2-wave antennas to the base station. Checked frequency range of the antennas with the frequency of the base station by correctly matching color codes.
- Connected 1/4-wave antenna to the beltack. Checked frequency range of the antennas with the frequency of the beltack by correctly matching color codes.
- Base station transmit power switches in the correct positions.
- Transmit mode switch on beltack set correctly
- Set wired intercom type correctly.
- Connected headsets to base stations (if needed) and all beltacks.
- Connected the base station to any auxiliary audio, intercom or external P.A. system.
- Installed batteries in the beltack.
- If you missed any of the above instructions, go back and complete that instruction before going on.

Frequency Plan Overview

The BTR/TR-700 has 36 factory defined frequency groups and 12 user-programmable frequency groups. A **Group** defines the base station transmit frequency and thus the receive frequency on all the beltacks. A **Channel** defines a base station receive frequency and thus a beltack transmit frequency. A base station receive channel that does not have a frequency set for it will have a dash to the right of it on the Group/Channel select screen. Details on setting frequencies may be found in the “BTR-700 Menu Structure” and “TR-700 Menu Structure” instructions in this section.

Factory-Defined Groups

The 36 factory-defined groups were carefully chosen to avoid certain intermod products and various other possible sources of interference. The Groups are set and cannot be changed. There is a limited number of channels which can be chosen from within these groups.

The first 24 factory-defined groups (01A – 12B) are “pair” groups that can be used for single (up to 4 beltacks) and dual (up to 8 beltacks) BTR-700 systems. They are arranged 01A, 01B, 02A, 02B...011B, 012A, 012B. A “pair” group, like 1A and 1B, have different base station transmit frequencies, however, they both have the same eight base station receive channels from which to choose. Each channel represents a unique frequency. For example, one BTR-700 could be set on Group 02A and channels 01, 02, 03 and 04. The other BTR-700 could be set on Group 02B channels 05, 06, 07 and 08. As long as the channels are different, everything should be fine.

The next 12 groups (13 – 24) are single groups that primarily are used for single (up to 4 beltacks) BTR-700 systems. The number of channels from which to choose from in these groups will vary from group to group.

User-Programmable Groups

The 12 user-programmable groups are initially empty. The transmit and receive frequencies are fully editable within these groups. In fact, factory-defined groups may be copied to user-programmable groups and then edited if desired. See the “BTR-700 Menu Structure” and “TR-700 Menu Structure” instructions in this section for details on how to copy and edit frequencies.

System Quick Start

Follow the list below to quickly get a base station and beltack(s) operating. When completed the user should have a base station and 1 to 4 beltacks up and running with full operational ability. The base station will be on Group 01A with its four receivers on channels 01, 02, 03 and 04. Each beltack will be on Group 01A with a unique transmit channel number matching one of the base station receive channels.

1. Plug-in the base station via the supplied power cord and connect the antennas. The color dots on the base should match the color rings on the antennas.
2. Base station rear panel switches: Transmit power set to High and on.
3. Ensure base station rear panel IC switch matches attached wired intercom system. If used stand alone or connected to a 4-wire system then IC switch position is Not Applicable.
4. Press [MENU] as powering-up the base station. This will place it on group 01A and set the receives on channels: 01, 02, 03, and 04.
5. Place the front panel IC “IN” and “OUT” level controls in the 12:00 o’clock position. Check that front panel IC is in 2-wire for AudioCom (Telex), RTS - TW and ClearCom wired systems, and 4-wire for RTS Matrix and stand-alone operation.
6. Place batteries in the beltacks.
7. Remove the rear switch cover on the beltacks. Set the beltack rear panel slide switch to push-to-talk (PT TALK).
8. Press [MENU] as powering-up each beltack. This will place the beltack on group 01A with the channel 01 flashing.
9. Use the [UP] and [DOWN] arrow buttons to change the channel to match a channel on the base station. Then press [SET]. If leaving on channel, just press [MENU]. Each beltack should have a unique channel number.
10. The group/channel on the beltack should now match the group and a receive channel on the base station. Nothing should be flashing on the beltack screens.
11. Plug headsets into the beltacks and set the microphone gain so the BAT/OM LED will flash at the beginning of most words at normal speech levels.

DONE.

Base Station Operation

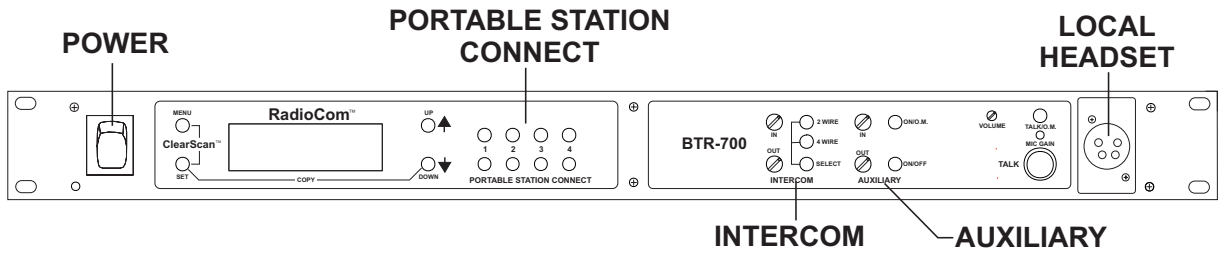

Base Station - Front Panel

Power

If you have followed the instructions in Section 4, “Initial Equipment Set-Up”, you should now be ready to turn the base station on.

Set the base station power switch to the on position, by pushing the top of the switch. The internal cooling fan will start immediately and the LCD display and front panel indicator lights will come on in five or six seconds.

Local Headset

Talk Button - Press to enable the audio path from the local headset. The TALK/O.M. LED will turn green when audio is enabled. A quick press and release latches on the button. If the talk function is latched on, pressing the talk button again will turn it off. If the local headset is not being used, the talk button should be off. This keeps additional noise out of the system.

Microphone Gain - Adjusts the headset’s microphone gain. Adjust so the TALK/O.M. LED flashes from green to red on loudest speech.

Volume - Adjust the volume to the headset by rotating the volume control as required for a comfortable listening volume.

Portable Station Connect

Select the audio paths from the base station’s four receivers that you wish to enable. The corresponding LED above the select button is on when the audio path is enabled. If a belt-pack user has their portable station connect path off at the base, that user will no longer hear their sidetone and their audio will not be passed to anyone. The user will still be able to hear everyone. The selection is retained in non-volatile memory, so it will come-up where last left if the unit is power cycled.

Always disable unused audio receive paths. This reduces the chances that external RF noise can get onto the audio buses via an open receiver.

Intercom

Intercom Select Button - Press the [SELECT] button to choose between 2-wire or 4-wire intercom systems. The green LED will indicate the current mode of the intercom channel. If the base station is connected to a 2-wire system, such as Audiocom (Telex), RTS TW or Clearcom, set the intercom to 2-wire. If it is connected to a four-wire system, such as RTS Matrix, set the intercom to 4-wire. The selection is retained in non-volatile memory, so it will come-up where last left if the unit is power cycled.

In Level Control - Adjusts the audio level of the wired intercom system’s input to the base station.

Out Level Control - Adjusts the audio level of the base station’s output to the wired intercom system.

If the base station is used stand-alone, no wired intercom system connected, it must be set in the 4-wire mode. The 2-wire mode requires a wired intercom system or appropriate load be connected to the intercom. If not loaded, a large gain increase will take place in the unload intercom channel which may be high enough to produce a loud “howling” sound.

Auxiliary

Auxiliary Input Select Button - Press the [SELECT] button to turn on or off the auxiliary input to the base station. The selection is retained in non-volatile memory, so it will come-up where last left if the unit is power cycled.

In Level Control - Adjusts the audio level of the wired auxiliary system’s input to the base station.

Out Level Control - Adjusts the audio level of the base station’s output to the auxiliary XLR plug.

The auxiliary output is always available at the back panel output XLR. It cannot be switch on or off like the input. Both the input and output are balanced audio ports.

Display Contrast

The LCD's (Liquid Crystal Display) contrast is set from the factory to a standard level. However it is possible for the user to adjust the contrast if desired. The contrast control is internal to the BTR-700 unit near the front panel. The cover must be removed for access to this control. Please see Figure 20 for the location.

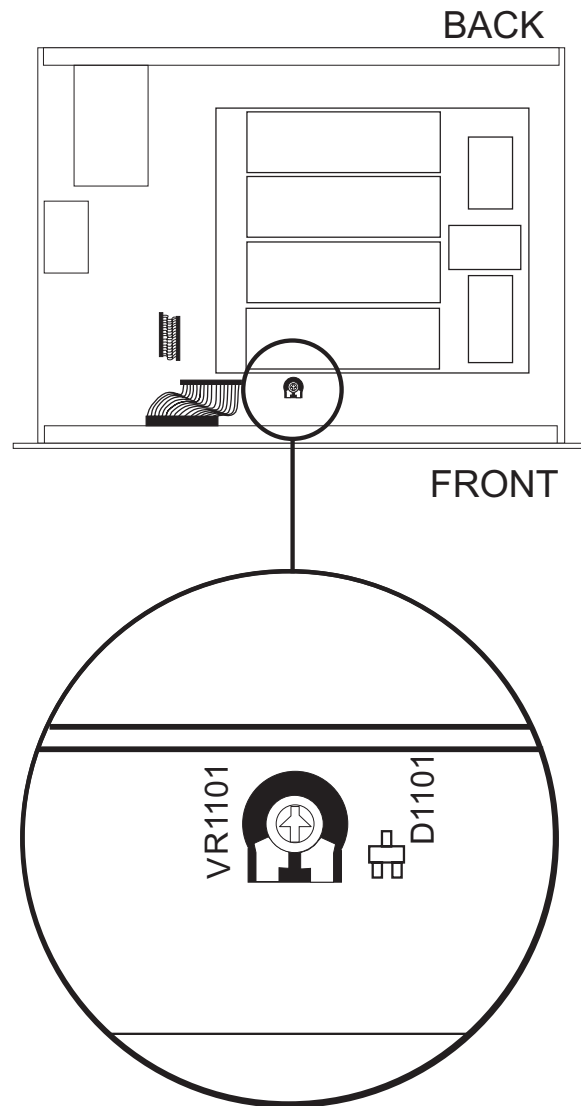
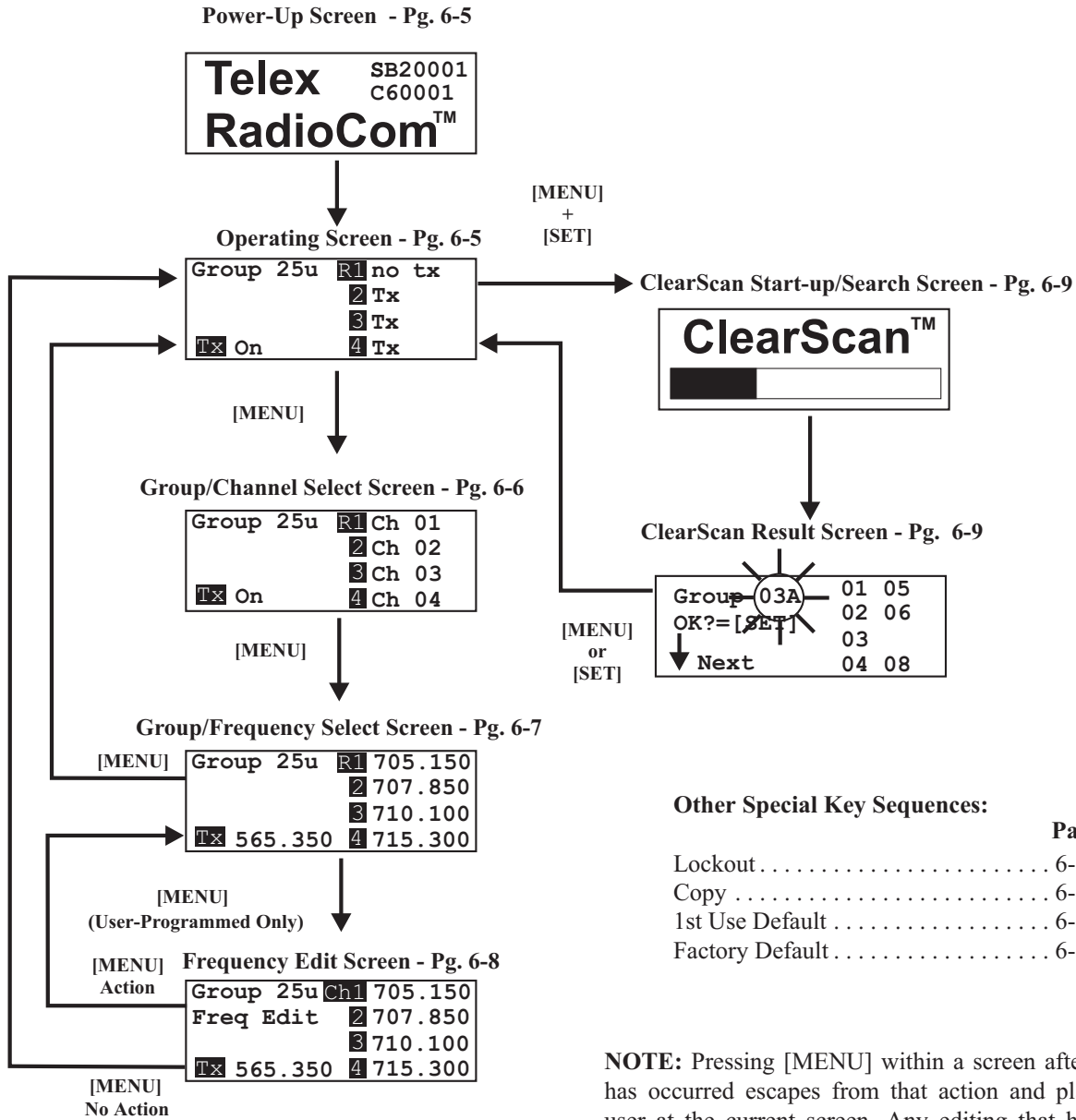

Figure 20
LCD Contrast

BTR-700 Menu Structure

Main Screen Flowchart

The following contains the base station menu structure and references the pages in which further detail of that menu may be found.



Other Special Key Sequences:

	Page
Lockout	6-10
Copy	6-10
1st Use Default	6-10
Factory Default	6-10

NOTE: Pressing [MENU] within a screen after action has occurred escapes from that action and places the user at the current screen. Any editing that had been done since [SET] had been pressed is aborted.

Power-Up Screen

- This screen is displayed only on power-up, first use default, and factory default.
- The 1st upper right corner number displays the base's software revision. The version number increments for changes in operational software.
- The 2nd upper right corner number displays the base's channel map (frequency plan) version. The version number increments for changes in the channel map.
- Once the power-up screen is displayed, it will change to the operating screen after a few seconds.

Operating Screen

- Screen is displayed after power-up screen.
- System will revert to this screen if no activity is detected on the LCD display buttons after 3 minutes.
- Screen displays current status of the system.

Beltpack Activity Code Definitions:

no tx = No Beltpack Transmit Carrier Detected
Off = Receiver is not selected on front panel
Tx = Beltpack is on

Power-Up Screen



Operating Screen

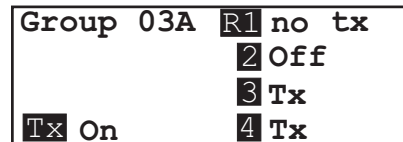

Group / Channel Select

The Group/Channel select screen allows the user to change the group and select from a pre-determined number of channels on each receiver.

- Hit [MENU] once to enter the Group / Channel Select Screen from the operating screen.
- Hit [SET] to enter group edit. The group number will start flashing. If [SET] is hit again without hitting the arrows, the display will go to receive 01 channel edit. **NOTE:** A channel that does not have a frequency set for it will have a dash to the right of it on the group/channel select screen.
- The [UP] / [DOWN] arrows will change the group number. Hit [SET] again to set the group that was flashing. Now the group number will stop flashing and R1's channel number will start to flash.
- The [UP] / [DOWN] arrows will change the receive channel number. Hit [SET] to set the channel that was selected. Now the second channel number will start to flash. If [SET] is hit again without hitting the arrows, the display will go to the next channel number.
- After the last receive channel is decided upon, hitting [SET] will set that channel in the unit and start you over at the beginning of the group/channel select screen with nothing flashing.
- Hitting [MENU] will take you to the group/frequency select screen. **NOTE:** Hitting [MENU] after activity has occurred within the screen will return to the group/channel select screen with nothing flashing. Any change that had been done before the last [SET] was pressed will be aborted.
- Setting two channels the same is not allowed. If a channel is already set on the screen, the user no longer has that channel as an option to set into one of the other receivers.

Group / Channel Select

Group 14	R1	Ch 01
	2	Ch 02
	3	Ch 03
Tx On	4	Ch 04

[SET]

Group 14	R1	Ch 01
	2	Ch 02
	3	Ch 03
Tx On	4	Ch 04

[UP] / [DOWN]
[SET]

Group 15	R1	Ch 01
	2	Ch 02
	3	Ch 03
Tx On	4	Ch 04

[UP] / [DOWN]
[SET]

Group 15	R1	Ch 02
	2	Ch 01
	3	Ch 03
Tx On	4	Ch 04

[UP] / [DOWN]
[SET] (Last Rx Changed)

Group 15	R1	Ch 05
	2	Ch 06
	3	Ch 07
Tx On	4	Ch 08

[MENU]

Group 15	R1	715.000
	2	716.700
	3	719.700
Tx 569.700	4	721.600

END

Group / Frequency Select

The Group/Frequency select screen allows a user to set the group and select from a pre-determined number of frequencies on each receiver. Each frequency displayed on the right half of the screen corresponds to a channel number in the Group/Channel Screen.

- Press [MENU] twice to go to the Group / Frequency Select screen from the operating screen. Hit [SET] to start the group number flashing.
- Press the [UP] / [DOWN] arrows to change the group number. The frequencies listed will reflect what is currently in that group. Hitting [SET] will select the group and start the selecting of predetermined frequencies within that group. The R1 frequency will start flashing. **NOTE:** The group number sets the transmit frequencies of factory defined groups and these are not editable. In user-programmed groups these are editable from the frequency edit screen.
- Pressing the [UP] / [DOWN] arrows will change the frequency of “R1” to the pre-defined frequencies available. Hitting [SET] will accept the change and start you editing the next channel. If you had not hit the arrow keys when the frequency was flashing, but instead hit [SET], you would have skipped to the next frequency to edit.
- After the last receive frequency is decided upon, hitting [SET] will save that last frequency and start you over at the beginning of the group/frequency select screen with nothing flashing.
- Pressing [MENU] will take you to the operating screen if this is a factory-defined group. If within a user programmed group, you will be taken to the frequency edit screen. **NOTE:** Hitting [MENU] after activity has occurred within the screen will return to the group/frequency edit screen with nothing flashing. Any change that had been done before the last [SET] was pressed will be aborted.

Group / Frequency Select

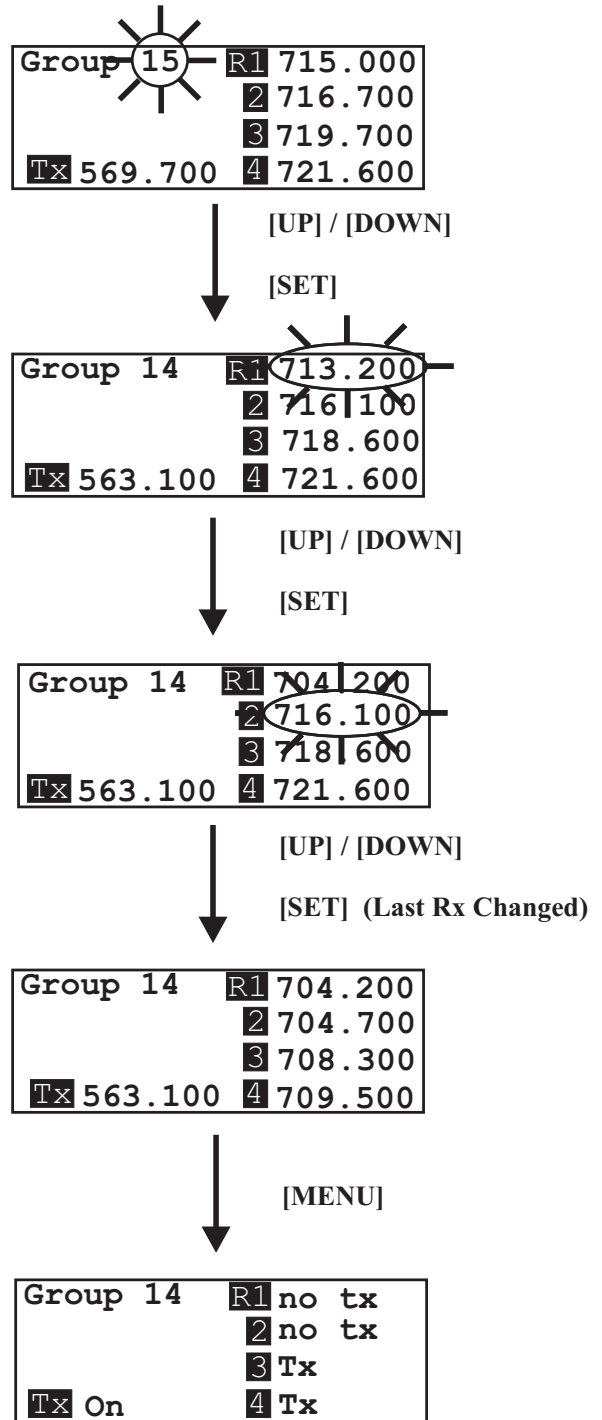

END

Frequency Edit (User-Programmed Groups Only)

This menu only occurs for user-programmable groups or when copying to a user-programmable group. The Frequency Edit screen allows the user to set the group transmit frequency and receive channel frequencies of a user-programmable group.

- Press [MENU] three times to go to the frequency select screen from the operating screen. Press [SET] to start the group number flashing. This screen allows the user to set the group and frequencies of user-programmed groups only.
- Press the [UP] / [DOWN] arrows to change the group number. The frequencies listed will reflect what is currently in that group. Dashes will be displayed in any slots that are not defined yet. Pressing [SET] will select the group and start the selecting of frequencies within that group. The Tx frequency will start flashing.
- Pressing the [UP] / [DOWN] arrows will change the frequency of “Tx” in 25kHz steps. Pressing [SET] will accept the change and start you editing Ch1. If you had not hit the arrow keys when the frequency was flashing, but instead press [SET], you would have skipped to the next frequency to edit.
- After editing the transmit and the receive channel frequencies, pressing [SET] will save that last frequency and send you over to the beginning of the group/frequency select screen with nothing flashing. **NOTE:** Once the end of the displayed channel list is reached, the last displayed channel location will scroll to allow the user to edit the remaining channels.
- After action has occurred in the frequency edit screen hitting [MENU] will take you one menu back to the group/frequency select screen so that the user may see what frequencies the base receivers are now on. If no action had occurred, then pressing [MENU] will take you to the operating screen. **NOTE:** Besides a group change, any editing that occurs within this screen to frequencies DOES NOT take effect until the user exits the screen via setting the last channel or pressing [MENU].

Frequency Edit (User-Programmed Groups Only)

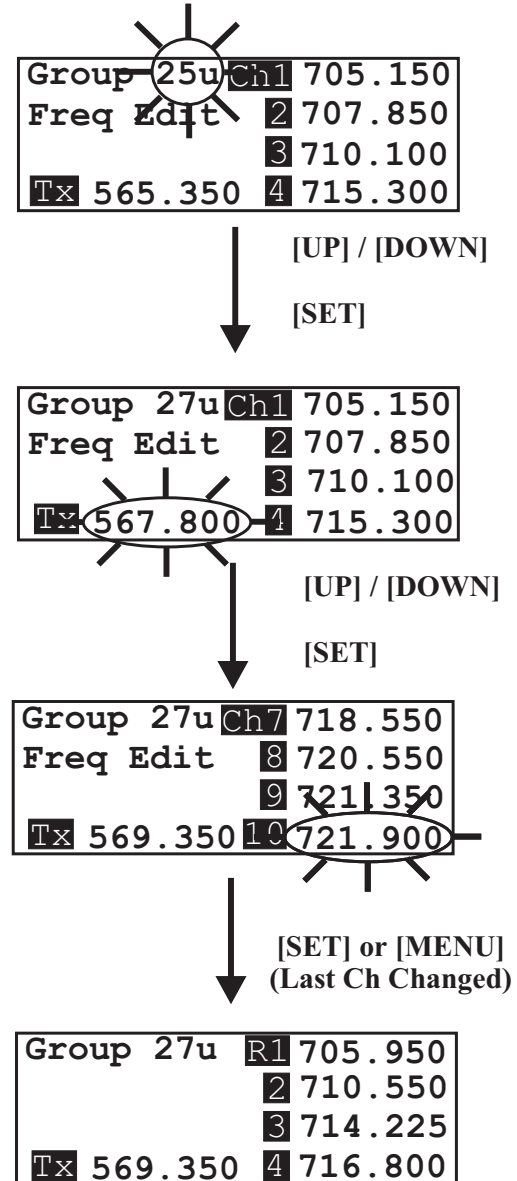

END

ClearScan™

ClearScan™ performs a frequency scan of the factory-defined and any set-up user-programmable groups in order to find the group with the highest number of clear receive channels. After about 20-30 seconds, the group with the highest number of clear receive channels will be displayed. The next best group and so forth may be accessed with the [DOWN] and [UP] arrow buttons.

- Press [MENU] + [SET] to enter ClearScan™. The base station will now start searching all groups for the ones with the greatest number of receiver channels clear of interference.
- ClearScan™ will display the group that has the most interference free receive channels. These clear channels are displayed on the right half of the screen. Press [SET] to place the base station on this group and return to the operating screen. The first four receive channels displayed will be the ones set for the group. The [UP] / [DOWN] buttons may be used to select the next best group and so forth.

ClearScan™

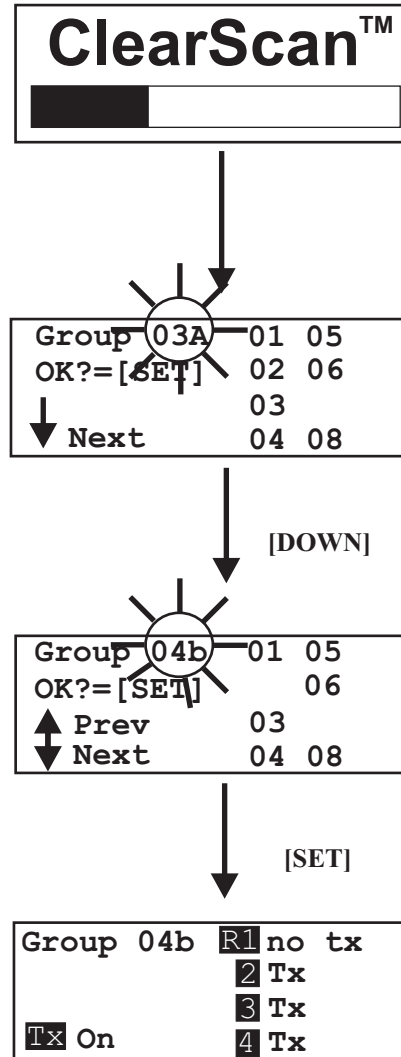

END

Special Key Sequences

Lockout

- Press [UP]+[DOWN] for 3 seconds to lock or unlock the base station. Pressing [MENU] will still function to view screens, but [SET] will no longer start any editing. ClearScan™, First use, Factory default are no longer accessible. The intercom front panel 2-wire/4-wire selection is also locked into place. A padlock icon will be displayed on the second line of the display to the far left as an indication that the base station is locked out.

Copy

- Press [SET]+[DOWN] for 3 seconds to copy any currently displayed group to a user-programmable group. Copy can be done from the group/channel select, group/frequency select or frequency edit screen. Once pressed, the words, “Copy to” are displayed on the screen with the first empty user-programmable group flashing. If all were user-programmed groups were full, then the first programable group is displayed. The [UP] or [DOWN] buttons may be used to select a different user-programmable group if desired. Pressing [SET] pastes frequencies/channels to the group and take the user to the frequency edit screen with “Tx” flashing.

1st Use Default

- Press [MENU] while turning on the base station to enter the 1st use default setup screen. This places the unit on group 01A with the four receivers set to channels 1- 4 of the group. **Any user-programmed frequencies that had been entered previously are retained.** If lockout had been activated, the beltpack comes up where it was last left regardless of [MENU] being pressed on power-up.

Factory Default

- Pressing all four buttons [MENU]+[SET]+[UP]+[DOWN] at the same time for 3 seconds places the unit on group 01A with the four receivers set to channels 1 – 4 of that group. This is just like base station 1st use default, except that **all user-programmed frequencies that had been entered previously are erased.** This function may take several seconds. If lockout had been activated, the beltpack comes up where it was last left regardless of these four keys being pressed.

Beltpack Operation

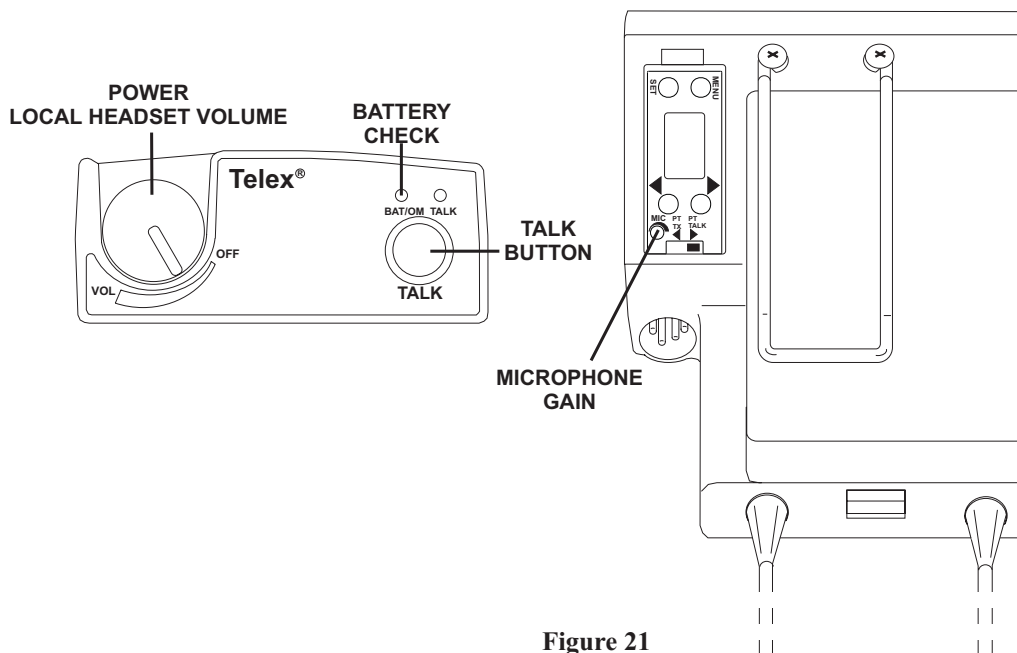

Figure 21
TR-700 - Top and Rear Panel

Power / Local Headset Volume

Turn the beltpack power on by rotating the knob CW. Adjust the volume to the headset by rotating the volume control as required for a comfortable listening volume.

Battery Check

When the beltpack power is turned on by rotating the knob, the BAT/OM LED will flash once if the battery is good. If the LED stays on, the battery is low. If the LED does not flash, the battery is dead.

Talk Button

Press the talk button to enable the audio path from the headset microphone. The TALK/OM LED will turn red when audio is enabled. A quick press and release latches the talk function unless latching has been disabled. Holding the button for over ½ a second will cause the audio path to be enabled only for as long as the button is held. If the talk function is latched on, pressing the talk button again will turn it off. See the “Talk Button Latching/non-Latching” instructions in Section 6 to learn how to enable/disable latching of the talk button.

Microphone Gain

Adjusts the headset’s microphone gain. Adjust so the TALK/OM LED flashes red at the beginning of most words at normal speech levels. If the input is too large, the LED will be red during the complete word at normal speech level. The peak-responding audio limiter in the beltpack is very tolerant of high input audio levels. Even when the microphone gain is maximized, and headset volume reduced to make up for the louder audio, the audio will still sound good and not clipped.

TR-700 Menu Structure

Beltpack Menu Structure

The following contains the main beltpack menu structure and references the pages in which further detail of that menu may be found.

All beltpack features and special key sequences can only be done from the group/channel screen.

Power-Up Screen - Pg. 6-13

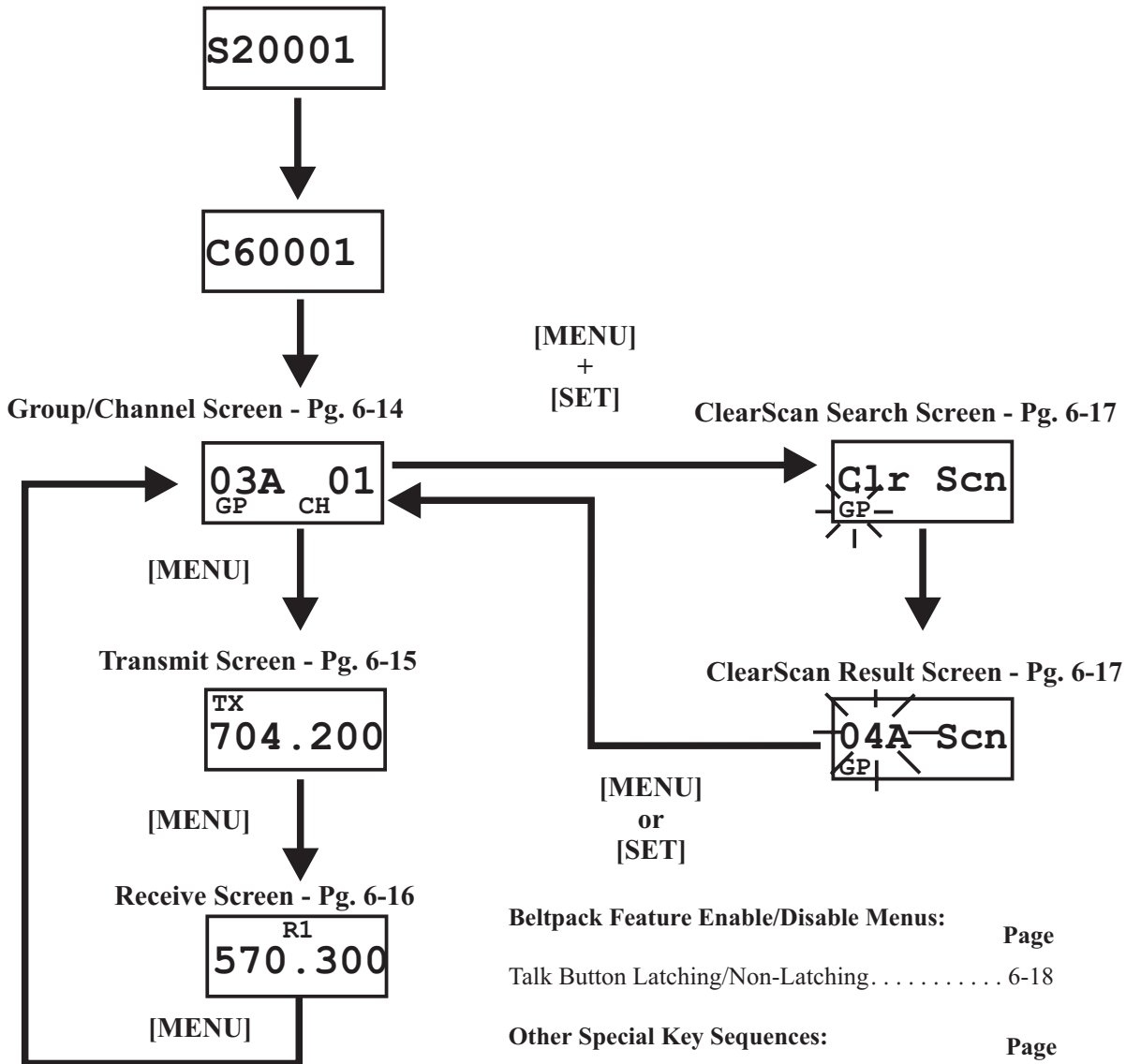

Beltpack Feature Enable/Disable Menus: Page

Talk Button Latching/Non-Latching 6-18

Other Special Key Sequences: Page

Lockout 6-18

1st Use Default. 6-18

Factory Default 6-18

NOTE: Pressing [MENU] within a screen after action has occurred escapes from that action and places the user at the current screen. Any editing that had been done since [SET] had been pressed is aborted.

Power-Up Screens

- The first screens displayed when the beltpack is powered up are the software and channel map version screens.
- The 1st screen displayed indicates the beltpack's software version number. It is displayed for about one second.
- The 2nd screen displayed indicates the beltpack's channel map (frequency plan) version number. It is displayed for about one second.
- The final screen displayed is the group/channel screen

Power-Up Screens

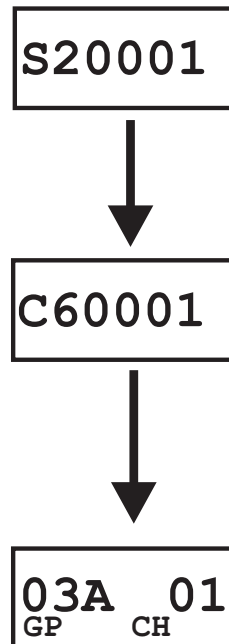

END

Group / Channel Screen

The Group/Channel screen allows the user to change the group and select from a pre-determined number of transmit channels.

- The screen displayed after the beltpack power-up screens.
- Press [SET] to edit the channel number. The channel number will start flashing.
- Use the [UP]/[DOWN] arrow buttons to change the channel number.
- Press [SET] to place the beltpack on the channel selected. Once set is pressed, the beltpack transmitter will move to that frequency and nothing will be flashing. Now press [SET] twice to enter group edit.
- Use the [UP]/[DOWN] arrow buttons to change the group number.
- Press [SET] to place the beltpack on the group selected. Once set is pressed, the unit returns to the group/channel display with nothing flashing.
- Pressing [SET] once more will start the editing sequence over again. Pressing [MENU] during the group edit will end editing and send the user back at the group/channel screen without any changes. This applies to channel editing too.

Group / Channel Screen

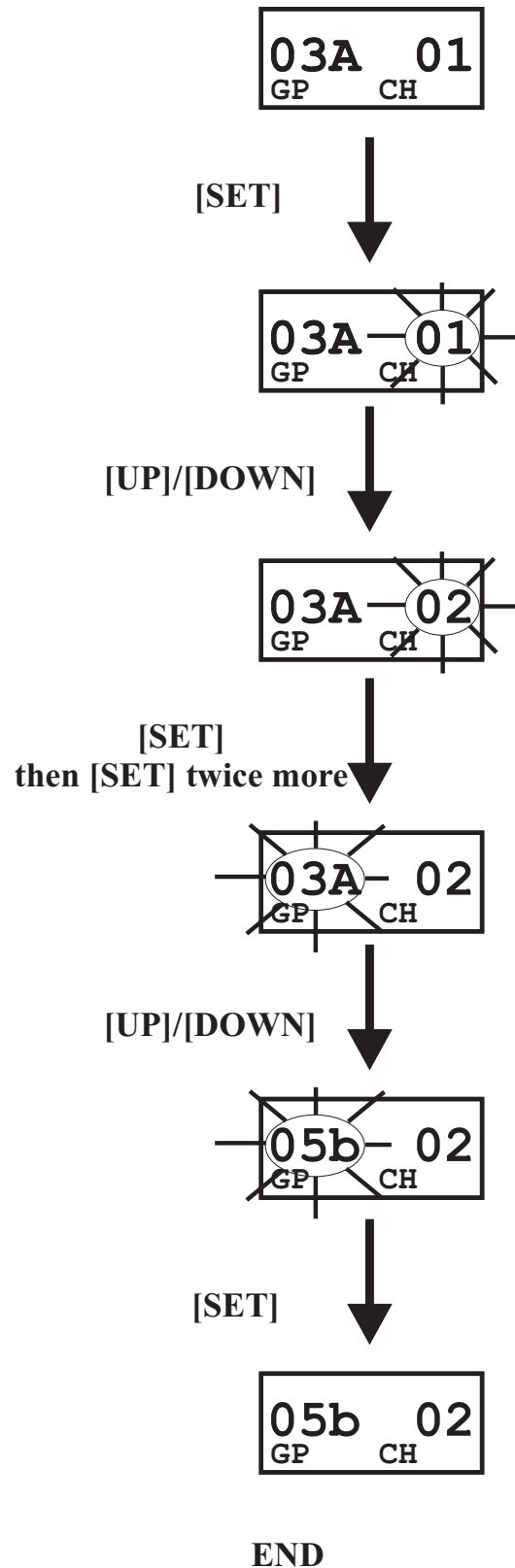

Transmit Screen

The Transmit screen allows the user to set the beltpack transmit frequency. Factory-defined groups will allow only a set number of pre-defined frequencies to be selected. User-programmable groups will allow the user to change the frequency in 25kHz steps.

- Press [MENU] once from the group/channel screen to arrive at the transmit frequency screen.
- Press [SET] to edit the frequency. The number will start flashing.
- Use the [UP]/[DOWN] arrow buttons to change the frequency.
- Press [SET] to place the beltpack on the frequency selected. If set is held down, during that time the group/channel is displayed so the user is aware of what transmit channel the unit has been placed. Once set is released, the unit returns to the transmit frequency screen with nothing flashing.
- Pressing [SET] once more will start the editing sequence over again. Pressing [MENU] during transmit frequency edit will end editing and send the user back to the transmit screen without any changes.

Transmit Screen

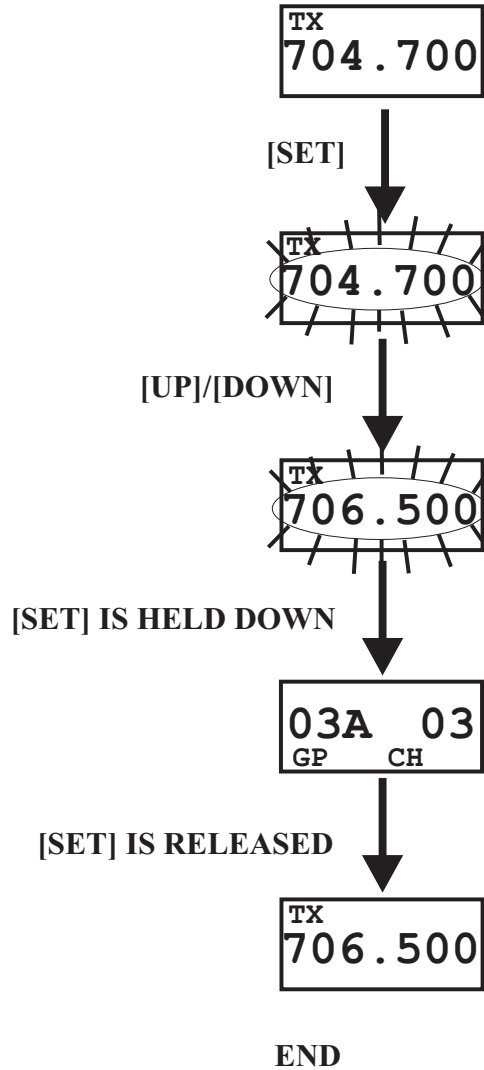

Receive Screen

The Receive screen allows the user to set the beltpack receive frequency. This corresponds to the base station's transmit frequency. In factory-defined groups receive is not changeable. User-programmable groups will allow the user to change the frequency in 25 KHz steps.

- Press [MENU] twice from the group/channel screen to arrive at the receive frequency screen.
- (User-Programmable Groups Only) Press [SET] to edit the frequency. The number will start flashing. Factory-defined groups can't be changed; so pressing set will do nothing at this screen. User-programmed groups will start flashing and allow the user to change the frequency in 25kHz steps.
- (User-Programmable Groups Only) Use the [UP]/[DOWN] arrow buttons to change the frequency.
- (User-Programmable Groups Only) Press [SET] to place the beltpack on the frequency selected. If set is held down, during that time the group is displayed so the user is aware of what group the unit has been placed. Once set is released, the unit returns to the receive frequency screen with nothing flashing.
- (User-Programmable Groups Only) Pressing [SET] once more will start the editing sequence over again. Pressing [MENU] during receive frequency edit will end editing and send the user back to the receive screen without any changes.

Receive Screen

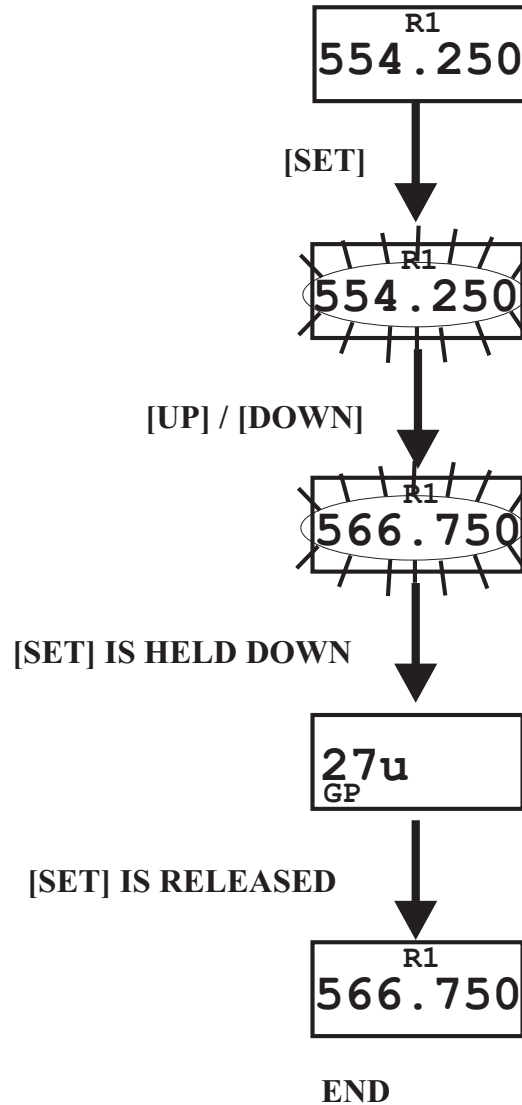

ClearScan™

ClearScan™ performs a frequency scan of the factory-defined and any set-up user-programable groups in order to find the clearest group. After about 30 seconds, the clearest group is displayed. A group is defined by the receive frequency. The next best group and so forth may be accessed with the [DOWN] and [UP] arrow buttons.

- Press and hold [MENU] + [SET] for three seconds to enter ClearScan™. The beltpack will now start searching for the clearest groups. The group symbol will flash indicating the beltpack is scanning for clear groups.
- ClearScan™ will scan all groups. It will then display the 1st group it came to that had the clearest receive channel. The [UP] / [DOWN] buttons may be used to select the next best group and so forth. Hit [SET] to place the beltpack on this group and return to the group/channel screen.

ClearScan™

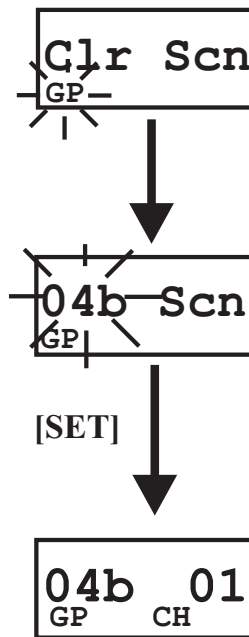

END

Talk Button Latch on/Latch off

- Press and hold [SET] then press the [TALK] button to show the Talk button Latch/non-Latching screen. The current setting of the feature is displayed on the LCD display.
- While continuing to hold [SET] press [TALK] again to toggle the display from on to off or back. Release the [SET] button to accept the current displayed setting and return to the Group/Channel screen.

HOLD [SET] AND PRESS [TALK]

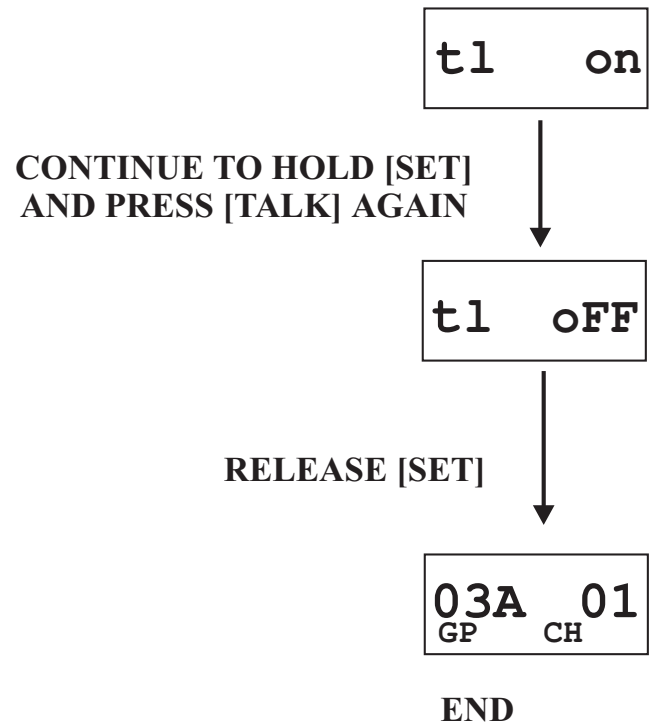

Special Key Sequences

Lockout

- Press [UP]+[DOWN] for 3 seconds to lock or unlock the beltpack. The words "Loc on" will be displayed when the feature is activated, "Loc off" will be displayed when the beltpack is unlocked. Pressing [MENU] will still function to view screens, but [SET] will no longer start any editing. ClearScan™, First use, Factory default and talk button latch on/latch off are no longer accessible.

1st Use Default

- Press [MENU] while turning on the beltpack to enter the 1st use default setup screen. This places the unit on group 01A with channel 01 flashing. **Any user-programmed frequencies that had been entered previously are retained.** The beltpacks must now be set to different transmit channels using the [UP]/[DOWN] buttons. Then [SET] is hit to place the units on those channels. If lockout had been activated, the beltpack comes up where it was last left regardless of [MENU] being pressed on power-up.

Factory Default

- Pressing all four buttons [MENU]+[SET]+[UP]+[DOWN] at the same time for three seconds places the unit on group 01A with channel 01 flashing, just like beltpack 1st use default, except the **all user-programmed frequencies that had been entered previously are erased.** After the buttons are released, it still may take several seconds for the beltpack to reset. The beltpacks must now be set to different transmit channels using the [UP]/[DOWN] buttons. Then [SET] is hit to place the units on those channels. If lockout had been activated, the beltpack comes up where it was last left regardless of these four keys being pressed.

Section 7

System Walk-Thru

Now that you have successfully “set-up” your Telex Wireless Intercom System and turned on any auxiliary equipment, you are ready to test the overall performance by “Walking” the Telex system through the areas in which you will be using it.

Before you begin your walk-thru, check the following:

- Beltpack Battery Check.
- Set microphone gain in both the beltpack(s) and the base station.
- The base station and beltpack(s) are on the same group and the beltpack(s) are on their own unique transmit channels that match the base station receive channels
- Check that the talk button is engaged. The talk LED will be illuminated.
- Intercom Level “IN” and “OUT” are set to an appropriate level.
- Auxiliary Level “IN” and “OUT” are set to an appropriate level (if used).

The “system walk-thru” can detect problem of weak signal strength caused by:

- Poor antenna location
- Wrong antenna for receiver and/ or transmitter
- RF “Trouble Spots”
- Operating distance beyond system capability.
- Old or used batteries in the TR-700.

Under normal conditions the base station’s display will indicate a beltpack status. “Weak Signal” condition will result in “no tx” being displayed on the base station’s receiver for that beltpack.

In 99% of all instances you will set up your Telex Wireless Intercom System, walk it through the area of interest and achieve error-free performance. If in the rare instance your Telex system does not “pass” during your walk-thru evaluation, refer to the section of this manual which deals with System Troubleshooting.

Section 8

Troubleshooting

Reread the sections of this manual to make sure you have completed system set-up properly.

If you are unable to solve the problem, contact the dealer from whom you purchased the system for assistance

PROBLEM	SOLUTION
DISTORTION - System's audio quality seems distorted at medium to high input levels.	Reduce microphone gain by adjusting microphone gain control.
HISS - System seems to produce a "hiss" which is undesirable.	Check the gain setting on all beltpacks and the base. They may be too low or too high. Check to make sure you are still well within range of the base station
LOW OUTPUT - System produces a low output level.	Check the gain setting on both the beltpacks and the base. They may be too low.
FEEDBACK - Moving around area of use produces "squeal" or "howl" in various locations using ext. speakers.	Reduce the gain settings on both the beltpacks and the base. They may be too high.
DROPOUTS - When moving around the area of use there seems to be locations where the signal "swooshes" or completely disappears.	Make sure both antennas on the base and beltpack are connected and follow the location suggestions. Change the location of the base unit and antennas or avoid the bad areas with the remote beltpacks.
INTERFERENCE - System picks up signals other than wireless Intercoms.	Make sure that all the Telex beltpack(s) are on. If there are any unused receivers at the base, turn the audio off from those receivers by deselecting the appropriate "Portable Station Connect" button. If problems persist with the beltpack on, you will probably need to change the group. Make sure the base and beltpack match after any Group/Channel change.
NO AUDIO from BASE or BELTPACK headsets.	Check Transmitter switch on base and beltpack. Check talk LED to make sure is on. Make sure beltpack batteries are OK.

Frequency Interaction

Unfortunately, radio frequency (RF) channels cannot be randomly selected for use in radio devices. They must be selected to avoid known frequencies in use, FCC restrictions on the location of devices, and even interference between your own RF devices. The factory defined frequencies (Groups 01A-24) selected by Telex for this RadioCom™ system are chosen to minimum possible interference.

Microphone Gain Adjustment

The microphone gain controls on the base station and belt-pack are set to mid-levels by the factory. In most cases this setting will work fine and only on loud speech will the overmodulation (OM) indicator light. However, in environments where the background noise is loud or the user has a strong/quiet voice, the gain control will need to be adjusted. In Figure 22 the gain is set correctly. The user's root-mean-square (RMS) sound level is well below the OM threshold and only on peaks does his or her voice flash the OM indicator light.

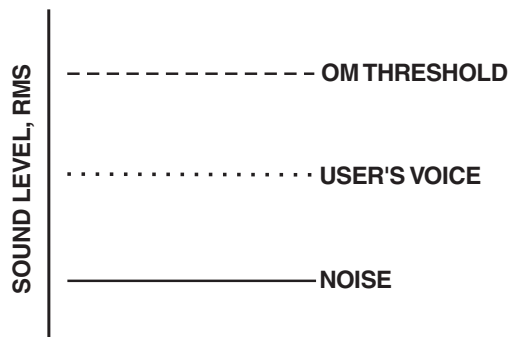

Figure 22
Low Noise Environment
Microphone Gain Set Correctly

Figure 23 displays the same gain setting as in Figure 22 but brought into a high noise environment. The user's voice now lights the OM indicator all the time he or she speaks due to the higher noise plus the user speaking louder. The result on the system is distortion on louder speech. The microphone gain must be reduced. The same applies to a user with a powerful voice. If someone sets the system mic gain to their voice and user has a much stronger voice, then the gain will need to be reduced, even if the background noise is the same.

Always remember to set the microphone gain based on the situation and location in which the equipment will be used. If the equipment is used on the field during a football game, set the gain based upon a loud stadium, NOT the quiet stadium 2 hours before a game. If a production studio user has a quiet voice, set the gain to their voice and NOT the stage hand's loud voice who helped set up the system.

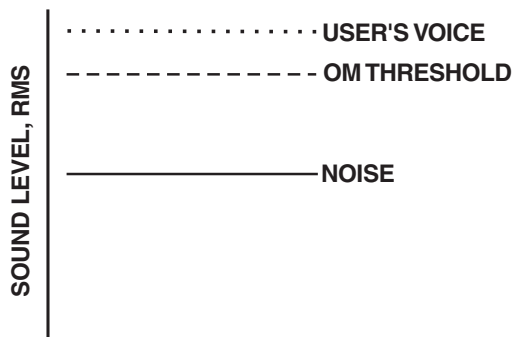

Figure 23
High Noise Environment
Microphone Gain Set Too High

Section 10

Battery Information

Improper battery selection, use, installation and care are the cause of numerous wireless system failures.

Alkaline Batteries: Alkaline batteries such as Mallory's DURACELL® or Eveready's ENERGIZER® provide the most reliable operation in wireless transceivers. Typical battery life of fresh alkaline batteries is 12 hours. **The use of low cost carbon-zinc batteries is NOT recommended.**

Nickel-Metal Hydride Batteries: These batteries can save you money in the long run, as they can be recharged. Typical battery life is 8 to 9 hours, which is about 70% of the length of time alkaline batteries last.

Energizer® is a registered trademark of Union Carbide Corporation.
Duracell® is a registered trademark of Duracell Inc.

Section 11

Intercom Systems Specifications

RTS

Input Impedance:200Ω
 Output Level:0.775 Vrms nominal
 Bridging Impedance:>10kΩ
 Call Signaling:
 Send:20kHz ±100 Hz, 240 mVrms
 Receive:20kHz ±800 Hz, 100 mVrms
 Power Voltage:28.0 VDC nominal

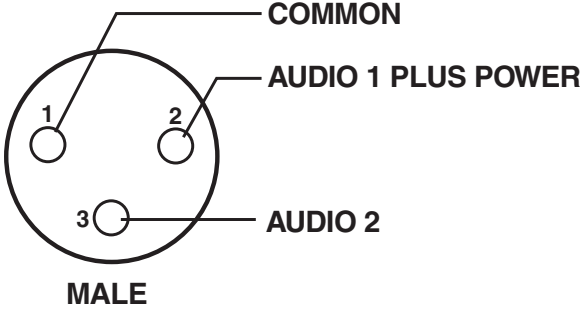

Diagram labels: COMMON, AUDIO 1 PLUS POWER, AUDIO 2, MALE

AudioCom/Telex

Input Impedance:300Ω
 Output Level:1.0 Vrms nominal
 Bridging Impedance:>10kΩ
 Call Signaling:
 Send:20kHz ±100 Hz, 05 mVrms
 Receive:20kHz ±800 Hz, 100 mVrms
 Power Voltage:24.0 VDC nominal

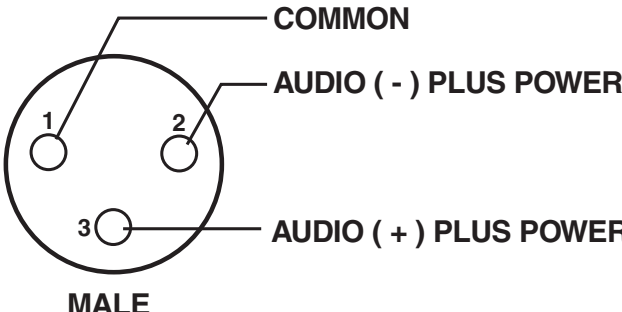

Diagram labels: COMMON, AUDIO (-) PLUS POWER, AUDIO (+) PLUS POWER, MALE

Clear-Com

Input Impedance:200Ω
 Output Level:1.0 Vrms nominal
 Bridging Impedance:>10kΩ
 Call Signaling:
 Send:12 ±3 VDC
 Receive:4 VDC Minimum
 Power Voltage:30.0 VDC nominal

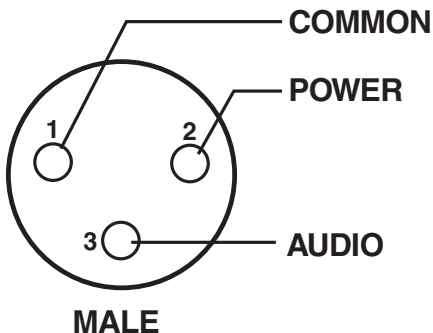

Diagram labels: COMMON, POWER, AUDIO, MALE

Section 12

Accessories and Replacement Parts

ALP-600

450-900 MHz Bi-Directional Log Periodic Antenna Includes mounting hardware and 10 feet (3 meters) of coaxial cable with TNC Connectors

P N. 878896



ALP-450

450-900 MHz Log Periodic Antenna Includes mounting hardware and 10 feet (3 meters) coaxial cable with TNC connectors



Order No. 71147000

Antenna Cables

Special low loss antenna cables with TNC Connectors

Model No.	Length	Order No.
CXU-10	10 Ft. (3 meter)	690419
CXU-25	25 Ft. (7.6 meter)	71151-025
CXU-50	50 Ft. (15 meter)	71151-050
CXU-75	75 Ft. (23 meter)	71151-075

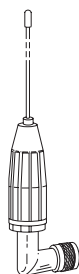

1/2-Wave Antenna

Base Station's 1/2 - Wave Antennas

Model No.	Part No.	Band Color	Frequency	C6	A2
CLA-3	870658-3	Red	615-659.9 MHz		Rx
CLA-5	870658-5	Green	690-724.9 MHz	Rx	
CLA-11	870658-11	Pink	515-548 MHz		Tx
CLA-12	870658-12	Brown	542-575 MHz	Tx	

AB-2

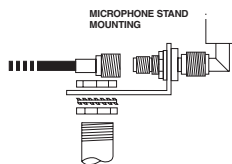

Bracket for 1/2 wave Antenna with 10 ft. of coax-

PN 71138000

BTR Power Cords

North America	550024013
U.K.	550024002
European	550024000
Australian	550024018

BTR Intercom Dummy Load

Telex type	PN 878935
RTS type	PN 878990

BP-700

TR Battery pack, alkaline

(batteries not included)PN 71315-000

BP-700NM TR Nickel Metal Hydride

Battery packPN 71315-001

BC-700NM4

Four Slot "Smart" Charger

with Four Nickel Metal Hydride Battery Packs

U.S./Canada71315400

Euro71315401

U.K.71315402

BC-700NM

Single Slot "Smart" Charger

with Nickel Metal Hydride Battery Pack

U.S./Canada71315100

Euro71315101

U.K.71315102

Beltpack's 1/4-wave antenna

	Part No.	Color Dot	Frequency	C6	A2
	879220-2	Black	485.0-553.9 MHz		Rx
	879220-3	Yellow	554.0-635.9 MHz	Rx	
	879220-4	Green	636.0-725.9 MHz	Tx	Tx

Customer Service Information

If your receiver or transmitter should need servicing, please contact:

Customer Service Department
TELEX COMMUNICATIONS, INC.
8601 East Cornhusker Highway,
Lincoln, Nebraska 68507-9702 U.S.A.
Phone: (402) 467-5321 or 1-800-553-5992

All claims of defect or shortage should be sent to the above address. When returning items for service, you must provide date and proof of purchase, such as a copy of the sales receipt, to establish warranty. A letter should be included outlining all symptoms and claimed defects. Information on how the equipment was installed and used is very helpful. Please include your phone number and return address in case our service technicians need to contact you.

Units that have been modified cannot be accepted for repair.

Include all information requested by the Service Department. Then pack the unit as follows:

Check the unit to see that all parts and screws are in place. Then wrap it in heavy paper or put it in a plastic bag. If the original carton is not available, place the unit in a strong carton that is at least six inches bigger in all three dimensions than the unit. Fill the carton equally around the unit with resilient packing material (shredded paper, foam, etc.). Seal it with gummed paper tape, tie it with a strong cord, and ship it by prepaid express, United Parcel Service or insured parcel post to the Telex Service Department.

It is very important that the shipment be well-packed and fully insured. Damage claims must be settled between you and the carrier and this can delay repair and return of the unit to you.

Telex reserves the right to make changes in design and improvement on its product without assuming any obligation to install the same on any of its products previously manufactured. Further Telex reserves the right to ship new and/or improved products which are similar to the form, fit and function of products originally ordered.

Section 14

Software License

End-User License Agreement for Telex® Software

IMPORTANT - Please read this document carefully before using this product.

THIS DOCUMENT STATES THE TERMS AND CONDITIONS UPON WHICH TELEX COMMUNICATIONS, INC. (the "COMPANY") OFFERS TO LICENSE THE INSTALLED SOFTWARE OR PROGRAM (the "SOFTWARE") FOR USE WITH THE PRODUCT IN WHICH IT WAS INSTALLED. YOU ARE AGREEING TO BECOME BOUND BY THE TERMS OF THIS AGREEMENT. IF YOU DO NOT AGREE TO THE TERMS OF THIS AGREEMENT, DO NOT USE THIS PRODUCT. PROMPTLY RETURN THE PRODUCT TO THE PLACE WHERE YOU OBTAINED IT FOR A FULL REFUND.

The installed software as supplied by the Company is licensed, not sold, to you for use only under the terms of this license, and the Company reserves all rights not expressly granted to you. You own the product or other media on or in which the Software is originally or subsequently recorded or fixed, but the Company retains ownership of all copies of the Software itself.

1. License: This license allows you to use the Software for internal purposes only on a single product in which it was installed.
2. Restrictions: (a) You may not market, distribute or transfer copies of the Software to others or electronically transfer or duplicate the software. YOU MAY NOT REVERSE ENGINEER, DECOMPILE, DISASSEMBLE, MODIFY, ADAPT, TRANSLATE, RENT, LEASE OR LOAN THE SOFTWARE OR CREATE DERIVATIVE WORKS BASED ON THE SOFTWARE OR ANY ACCOMPANYING WRITTEN MATERIALS. (b) The Software and the accompanying written materials are copyrighted. Unauthorized copying of the Software, including portions thereof or the written materials, is expressly forbidden. (c) You understand that the Company may update or revise the Software and in so doing incurs no obligation to furnish such updates to you.
3. Limited Warranty: The company does not warrant that the operation of the Software will meet your requirements or operate free from error. The company DISCLAIMS ALL OTHER WARRANTIES AND CONDITIONS EITHER EXPRESS OR IMPLIED, INCLUDING THE WARRANTIES OF MERCHANTABILITY, FITNESS FOR A PARTICULAR PURPOSE AND NON-INFRINGEMENT OR THIRD PARTY RIGHTS.
4. Limited Liability: The liability of the company for any claims arising out of this License based upon the Software, regardless of the form of action, shall not exceed the greater of the license fee for the Software or \$50.

FCC LICENSING

The Telex BTR-700 and the TR-700 Transmitter/Receiver are Type Accepted under United States Federal Communications Commission Part 74. Licensing of Telex equipment is the User's responsibility and licensibility depends on the user's classification, users application, and frequency selected. Telex strongly urges the user to contact the appropriate telecommunications authority for any desired clarification.

CAUTION: Changes or modifications made by the user could void the user's authority to operate the equipment.

Mandatory Safety Instructions to Base Station Installers and Users

1. Use only manufacturer or dealer supplied antenna.

Antenna Minimum Safe Distance: 20 cm

Antenna Gain: zero dBd referenced to a dipole.

2. The FEDERAL COMMUNICATIONS COMMISSION has adopted a safety standard for human exposure to RF (Radio Frequency) energy, which is below the OSHA (Occupational Safety and Health Act) limits.
3. Antenna Mounting: The antenna supplied by the manufacturer or radio dealer must not be mounted at a location such that during radio transmission, any person or persons can come closer than the above indicated minimum safe distance to the antenna i.e. 20 cm.
4. To comply with current FCC RF Exposure limits, the antenna must be installed at or exceeding the minimum safe distance shown above, and in accordance with the requirements of the antenna manufacturer or supplier.
5. Base Station Installation: The antenna should be fixed-mounted on an outdoor permanent structure. RF Exposure compliance must be addressed at the time of installation.
6. Antenna substitution: Do Not substitute any antenna for the one supplied or recommended by the manufacturer or radio dealer. You may be exposing person or persons to harmful radio frequency radiation. You may contact your radio dealer or the manufacturer for further instructions.
7. **WARNING:** Maintain a separation distance from the antenna to person(s) of at least 20cm.

You, as the qualified end-user of this radio device must control the exposure conditions of bystanders to ensure that the minimum separation distance (above) is maintained between the antenna and nearby persons for satisfying RF Exposure compliance.

The operation of this transmitter must satisfy the requirements of the Occupational/Controlled Exposure Environment for work-related use. Transmit only when person(s) are at least the minimum distance from the properly installed, externally mounted antenna.

Section 16

Limited Warranty

Limited Warranty (Valid United States and Canada Only)

TELEX Communications, Inc. ("Telex") warrants to the user, who originally purchased the serialized product delivered with this card, that the product will be free from defects in material and workmanship for the following periods after such date of purchase. Material 36 months, workmanship 36 months. Microphones, earphones, neckloops, cables & connectors are warranted for ninety days. Telex will, at its option, repair or replace free of charge such defective products subject to the following conditions:

1. Delivery of the product or parts postage prepaid to the Telex dealer, authorized service facility or factory.
2. Determination by Telex that a defect exists and is covered by limited warranty. Defects due to alteration, repair by unauthorized persons, insertion of non-Telex parts, misuse, accidental damage, use of the equipment for purposes other than those for which it was designed, and the like, are not covered by this limited warranty and repairs thereof will be subject to normal service charges.
3. Repairs and replacement parts are covered under this limited warranty only for the unexpired term of the original limited warranty.
4. Products purchased from unauthorized dealers are not warranted.
5. You must fill out and return the product warranty card to register the purchase date of serialized items. A copy of the bill of sale showing the date of purchase must accompany all warranty work.

THIS LIMITED WARRANTY IS EXPRESSLY IN LIEU OF ANY EXPRESS OR IMPLIED WARRANTY, INCLUDING ANY IMPLIED WARRANTY OR MERCHANTABILITY OR FITNESS FOR A PARTICULAR PURPOSE WHICH EXTENDS BEYOND THE TERM HEREOF. THE REMEDIES PROVIDED BY THIS LIMITED WARRANTY ARE THE ONLY REMEDIES AVAILABLE TO ANY PERSON. NO PERSON HAS ANY AUTHORITY TO BIND TELEX TO ANY REPRESENTATION OR WARRANTY OTHER THAN THOSE PROVIDED BY THIS LIMITED WARRANTY. TELEX SHALL NOT BE LIABLE FOR ANY INCIDENTAL OR CONSEQUENTIAL DAMAGES CAUSED BY FAILURE OR OTHERWISE OF THE PRODUCT.

Some states do not allow exclusions or limitations of incidental or consequential damages or limitations on how long an implied warranty lasts, so the limitations or exclusions herein may not apply to you. This warranty gives you specific legal rights, and you may also have other rights which vary from state to state.

TELEX[®]

TELEX COMMUNICATIONS, INC. • 12000 Portland Ave. South, Burnsville, MN 55337.

PN 803290

OCT 2001

Made in U.S.A.